

UNI

ED. 7/2024



UNICOLLECTION

Il catalogo Uni Collection si arricchisce di nuove serie con modelli contemporanei e innovativi per soddisfare le attuali richieste dei propri utenti di prodotti più smart. Lo standard qualitativo, grazie alla scelta di realizzare ogni prodotto con componentistica e materiali **100% Made in Italy**, è sempre elevato e competitivo sul mercato con un ottimo rapporto qualità/prezzo. Sempre attenta all'innovazione, Sesta, ove possibile, utilizza materiali e concetti produttivi green, mantenendo elevati gli aspetti affidabilità e di perennità del prodotto con garanzia di **5 anni sulle parti meccaniche**.

LIGHTNESS. VERSATILITY. GREEN.

EN

The Uni Collection catalogue has been expanded to include new ranges with contemporary and innovative models to meet its users' current demands for smarter products. The high standard of quality - achieved by choosing to manufacture each product with **100% Made in Italy components and materials** - continues to be competitive on the market with an excellent quality/price ratio. Sesta always focuses on innovation and, where possible, uses **green materials and production concepts**, keeping the product's **reliability and durability high**, with a **5-year warranty on mechanical parts**.

FR

Le catalogue Uni Collection s'enrichit de nouvelles séries avec des modèles contemporains et innovants pour satisfaire les demandes actuelles des clients orientés vers des produits plus «smarts». Le niveau de qualité, grâce au choix de fabriquer chaque produit avec des **composants et des matériaux 100 % Made in Italy**, est toujours élevé et compétitif sur le marché avec un excellent rapport qualité/prix. Toujours attentive à l'innovation, Sesta utilise, quand cela est possible, des **matériaux et des concepts de production écologiques**, tout en assurant des aspects élevés de **fiabilité et de pérennité du produit** avec une **garantie de 5 ans sur les parties mécaniques**.

D

Der Katalog Uni Collection wird durch neue Reihen mit zeitgemäßen und innovativen Modellen bereichert, um den aktuellen Anforderungen der Nutzer nach intelligenteren Produkten gerecht zu werden. Der Qualitätsstandard ist dank der Entscheidung, jedes Produkt mit **Bauteilen und Materialien 100% Made in Italy** herzustellen, stets hoch und mit einem ausgezeichneten Preis-Leistungs-Verhältnis auf dem Markt wettbewerbsfähig. Sesta ist stets auf Innovation bedacht und setzt, wo immer möglich, umweltfreundliche **Materialien und Produktionskonzepte ein**, während gleichzeitig die **Zuverlässigkeit und Dauerhaftigkeit** der Produkte mit einer **5-Jahres-Garantie auf mechanische Teile** gewährleistet ist.

UNICOLLECTION

EXECUTIVE



008 Chic



020 My Mesh



030 Master



036 Jolly

TASK



054 X1

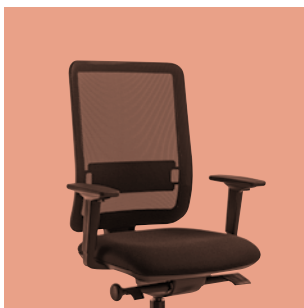

068 Twist



080 Twist TT

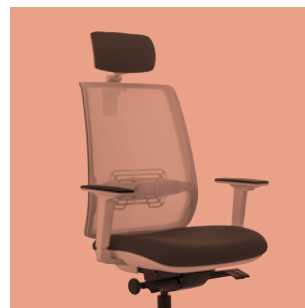

088 Cobra

**VISITORS/
CONFERENCE**



130 1000 Plus



148 1000 Revo



164 Jx

**LOUNGE/
WAITING**



176 Così



192 Gemma



200 Dolly



208 Ken



044 Silver 2100



098 Cobra TT



104 CO2/22



114 Viva



122 Dattilo Golf 21



220 Boy



226 Mito



232 Tago



238 Quadro

NOVITÀ UNI

NEWS
NOUVEAUTÉS
NEUHEITEN

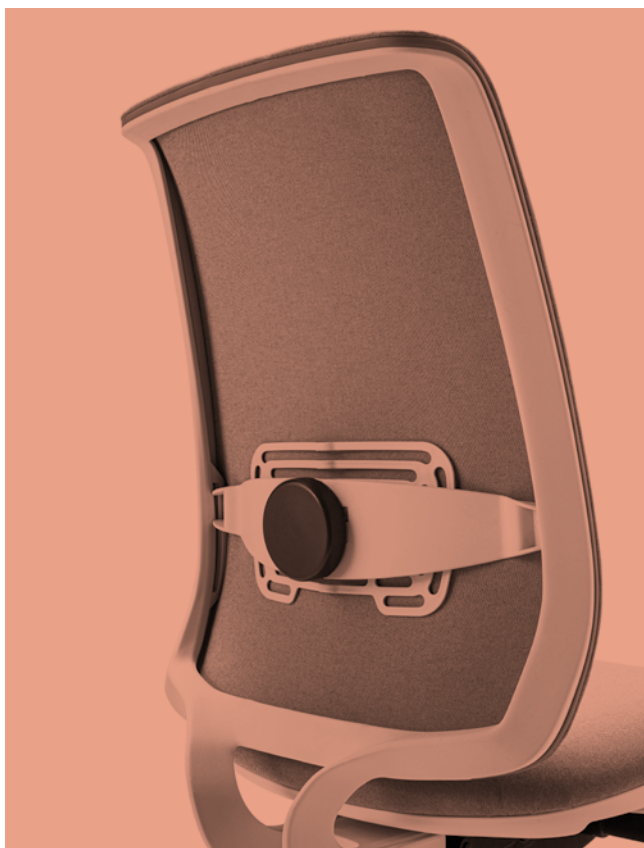





EXECUTIVE

008	Chic
020	My Mesh
030	Master
036	Jolly
044	Silver 2100



Chic

EXECUTIVE

I

Direzionale dal design contemporaneo – ideale per arredare sale riunioni o zone di incontro –, Chic è caratterizzata dalla leggerezza estetica e dall'imbottitura soffice e vaporosa, valorizzata da rivestimenti in pelle o materici.

Proposta con raffinati braccioli corti a sbalzo in alluminio, è disponibile in tre dimensioni di schienale. È apprezzata da un pubblico dinamico, attento alla qualità del dettaglio e alle forme minimaliste.

EN

Chic – an executive chair with a contemporary design – is perfect for meeting rooms or gathering areas, and stands out for its aesthetic lightness and soft, airy padding, set off by leather or fabric upholstery.

Proposed with stylish short cantilevered aluminium armrests, it is available with three backrest sizes. It is appreciated by a discerning, dynamic user who values quality details and minimalist shapes.

FR

Fauteuil de direction au design contemporain – idéal pour les salles de réunion ou les espaces de rencontre –, Chic est caractérisé par la légèreté esthétique et par le rembourrage moelleux et douillet, valorisé par les revêtements en cuir ou texturés. Proposé avec des accoudoirs courts raffinés cantilever en aluminium, il est disponible en trois hauteurs de dossier. Il est apprécié par un public dynamique, attentif à la qualité du détail et aux formes minimalistes.

D

Der Chefsessel Chic im zeitgemäßen Design ist ideal zur Einrichtung von Konferenzräumen oder Meetingbereichen und zeichnet sich durch ästhetische Leichtigkeit sowie eine weiche und luftige Polsterung aus, die durch Leder- oder Stoffbezüge optimal ergänzt wird.

Er ist mit raffiniert gestalteten, freitragenden Kurzarmlernen aus Aluminium ausgestattet und mit drei Rückenlehnenhöhen erhältlich. Besonders gut kommt er bei einem dynamischen Publikum an, das Wert auf Qualität im Detail legt und minimalistische Formen schätzt.



Mod. CC-002U



Mod. CC-013U



Mod. CC-063U



Mod. CC-098U + op. CC-FPE



Mod. CC-072U



Mod. CC-002U + op. CC-FPE
Mec. TX36



Mod. CC-004U + op. CC-FPE
Mec. A19



Mod. CC-006U + op. CC-MIX
Mec. A19

Mod. CC-001U + op. CC-MIX
Mec. TX36



Mod. CC-005U + op. CC-FPE
Mec. A19

Mod. CC-091U + op. A45-PP-LU + op. CC-FPE



Op. CC01-BPI



Mod. CC-013U
Mec. TX36

Mod. CC-015U + op. CC-MIX
Mec. A19



Mod. CC-021U + op. A45-PP-N
Mec. A20G

Mod. CC-019U
Mec. A20G













My Mesh

EXECUTIVE

I

Tecnologica e moderna caratterizzata da un disegno leggero ed aereo, ideale per un pubblico giovane e dinamico, alla ricerca di funzionalità e design. La struttura, in abbinamento alla rete, sembra essere impercettibile, ma tecnologia e qualità dei materiali impiegati la rendono resistente alle più alte sollecitazioni dinamiche. My Mesh è proposta con struttura bianca in abbinamento alla rete nera o grigia, e con struttura nera in abbinamento alla rete nera.

EN

Technological and modern, featuring a light and airy design, this is ideally suited to a young, active public seeking functionality and design. The structure, coupled with the mesh, seems to be barely noticeable, but the technology and quality of the materials make it resistant to the most extreme dynamic stresses. The My Mesh proposals include white structure coupled with black or grey mesh, and black structure coupled with black mesh.

FR

Technologique et moderne, caractérisé par un design léger et aérien, idéal pour un public jeune et dynamique, à la recherche de fonctionnalité et de design. La structure, associée à la résille, semble être imperceptible, mais la technologie et la qualité des matériaux employés la rendent résistante aux plus fortes sollicitations dynamiques. My Mesh est proposé avec la structure blanche associée à la résille noire ou grise, et avec la structure noire associée à la résille noire.

D

Moderne, technische Reihe, die durch ihre ästhetische Leichtigkeit gekennzeichnet ist, ideal für ein junges und dynamisches Publikum auf der Suche nach Funktionalität und Design. Das Gestell erscheint in Verbindung mit der Netzbespannung kaum wahrnehmbar, hält jedoch dank der technischen Ausstattung und Qualität der verwendeten Materialien den höchsten dynamischen Belastungen stand. Erhältlich ist My Mesh mit weißem Gestell und schwarzer oder grauer Netzbespannung sowie mit schwarzem Gestell und schwarzer Netzbespannung.



Mod. MM-W01U



Mod. MM-002U + op. MM-BRC-N



Mod. MM-W08U



Mod. MM-016U



Mod. MM-W11U



White Mod. MM-W01U

White Mod. MM-W04U







White Mod. MM-W06U + op MM-BRC-W

White Mod. MM-W08U

White Mod. MM-W12U

White Mod. MM-W11U







Black Mod. MM-016U





Master

EXECUTIVE

I

Direzionale dal confort e prestazioni elevate. La serie si valorizza con l'impiego dei braccioli in alluminio lucidato con pad di serie in Poliuretano oppure con pad tappezzato; i braccioli in alluminio si abbinano perfettamente ai supporti in alluminio della versione con poggiatesta, conferendo così alla poltrona un alto valore estetico. Proposta con solo il meccanismo Synchro SY9 dotato di traslatore del sedile SLY e basi Ø 70 cm in alluminio lucido (LU) o in Nylon colore nero (NY). Ospiti su slitta con schienale alto in abbinamento alla poltrona direzionale.

EN

Executive chair with outstanding comfort and performance. The series is set off by the use of polished aluminium armrests with standard Polyurethane pads or upholstered pads; the aluminium armrests perfectly match the aluminium supports of the version with headrest, giving the chair a high-end look. Proposed with the Synchro SY9 mechanism only, equipped with SLY seat slider and Ø 70 cm bases in polished aluminium (LU) or black Nylon (NY). Visitor chairs on sled base with high backrest, matching the executive chair.

FR

Fauteuil de direction au confort et aux performances élevées. La série est mise en valeur par l'utilisation d'accoudoirs en aluminium poli avec manchettes standard en polyuréthane ou rembourrées; les accoudoirs en aluminium sont parfaitement assortis aux supports en aluminium de la version avec appuie-tête, donnant ainsi au fauteuil une haute valeur esthétique. Proposé uniquement avec le mécanisme Synchro SY9 muni de translation de l'assise SLY et piètements Ø 70 cm en aluminium poli (LU) ou en nylon de couleur noire (NY). Version visiteur sur piètement luge avec dossier haut à associer au fauteuil de direction.

D

Der komfortable Chefsessel mit umfassenden Leistungsmerkmalen. Die Reihe wird durch die Armlehnen aus poliertem Aluminium mit standardmäßiger Auflage aus Polyurethan oder gepolsterter Auflage bereichert; die Armlehnen aus Aluminium passen perfekt zu den Halterungen aus Aluminium der Version mit Kopfstütze und verleihen dem Sessel ein hochwertiges Aussehen. Wird nur mit Synchro-Mechanismus SY9 mit Sitzflächenverschiebung SLY und Fußkreuz Ø 70 cm aus poliertem Aluminium (LU) oder schwarzem Nylon (NY) angeboten. Besuchersessel als Freischwinger mit hoher Rückenlehne, passend zum Chefsessel.



Mod. MR-001U + op. 10BH



Mod. MR-007U + op. 10BH

Mod. MR-007U
+ op. 5B/LU + A25-50

Mod. MR-011U



Mod. MR-002U + op. 5B/LU + op. MR-022U
Mec. SY9

Mod. MR-006U + op. 8BRA
Mec. SY9



Mod. MR-002U + op. 5B/LU-BPI
Mec. SY9

Mod. MR-012U + op. MR-021U



Mod. MR-007U + op. 5B/LU + A25-50
Mec. SY9





Jolly

EXECUTIVE

I

Poltrona molto versatile che esprime la propria identità grazie alla scelta di dettagli tecnici importanti, quali la tappezzeria (con fodera frontale amovibile) e la dotazione di un meccanismo oscillante a fulcro centrale A19, blocco in 1 posizione, tarabile in funzione del peso con manopola, molto affidabile e pratico. La serie si compone di sedie direzionali e ospiti, tutte proposte in 3 versioni: RETE (monotelo di rete PVC nei colori nero e bianco); TAP-RE sedile tappezzato e schienale in rete e TAP completamente tappezzata, con disponibilità in tutti i rivestimenti a cartella. La struttura e i braccioli sono realizzati in acciaio cromato (CR) e base Ø 70 cm in alluminio lucido (LU).

EN

A very versatile chair that expresses its own identity thanks to the choice of striking technical details, such as the upholstery (with removable front cover) and the provision of the central tilt mechanism (A19), lockable in 1 position, weight-adjustable by means of knob, very reliable and practical. The series consists of executive and visitor chairs, each available in 3 versions: RETE (single-layer PVC mesh in black and white); TAP-RE (upholstered seat and mesh backrest); and TAP (fully upholstered, available with all listed coverings). The structure and armrests are made from chrome finish steel (CR) with Ø 70 cm base in polished aluminium (LU).

FR

Fauteuil très polyvalent qui exprime son identité grâce au choix de détails techniques importants, comme le revêtement (avec housse frontale amovible) et la présence d'un mécanisme basculant à axe central A19, blocage sur 1 position, réglable en fonction du poids avec poignée, très fiable et pratique. La série se compose de fauteuils de direction et visiteurs, tous proposés en 3 versions: RETE (toile unique en résille PVC noire ou blanche); TAP-RE assise tapissée et dossier en résille et TAP complètement tapissé, avec tous les revêtements du nuancier. La structure et les accoudoirs sont en acier chromé (CR) et le piètement Ø 70 cm en aluminium poli (LU).

D

Ein sehr vielseitiger Sessel, der seine Identität durch wichtige technische Details ausdrückt. Dazu gehören die Polsterung (mit frontseitig abnehmbarem Bezug) und die Wippmechanik mit zentralem Drehpunkt A19, in 1 Position arretierbar und per Drehknopf nach Gewicht einstellbar - äußerst zuverlässig und praktisch. Die Reihe besteht aus Chefsesseln und Besucherstühlen, die alle in 3 Ausführungen angeboten werden: RETE (einlagige Netzbespannung aus PVC in schwarz und weiß); TAP-RE gepolsterter Sitz und Rückenlehne mit Netzbespannung und TAP vollständig gepolstert, mit allen Bezügen nach Stoff-Mustermappe erhältlich. Gestell und Armlehnen sind aus verchromtem Stahl (CR) während das Fußkreuz Ø 70 cm aus poliertem Aluminium (LU) besteht.



Mod. JY-252U
Mec. A19



Mod. JY-332U
+ JY-032U + JY-030U
Mec. A19



Mod. JY-337U
Mec. A19



Mod. JY-322U



Mod. JY-272U + op. JY-033U
Mec. A13



TAP Mod. JY-332U
Mec. A19

RETE Mod. JY-252U
Mec. A19



TAP Mod. JY-337U + op. JY-032U
Mec. A19

TAP-RE Mod. JY-302U
Mec. A19







TAP Mod. JY-332U + JY-032U + JY-030U TAP-RE Mod. JY-322U
Mec. A19



TAP-RE Mod. JY-302U
Mec. A19

TAP Mod. JY-347U + op. JY-032U + op. A21-70
Mec. A19



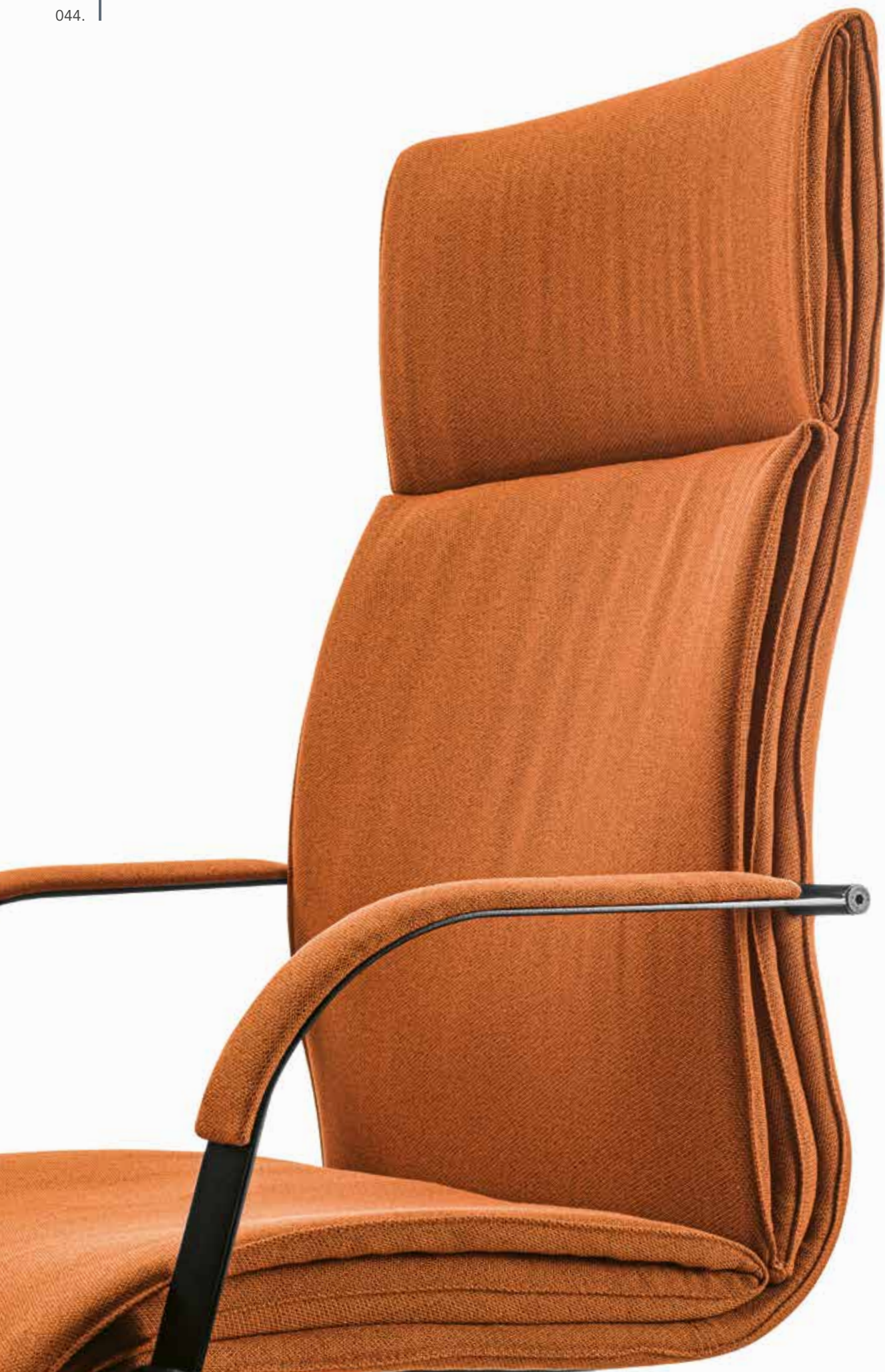

Silver 2100

EXECUTIVE

I

Serie direzionale caratterizzata da dettagli importanti: spessori sottili che le conferiscono eleganza, ottima qualità della tappezzeria e braccioli in acciaio di fattura, rendendola ideale per essere abbinata a tavoli e scrivanie dal design minimalista. L'imbottitura, pur essendo compatta, offre un ottimo confort, grazie al disegno ergonomico della monoscocca. I braccioli, realizzati in piatto d'acciaio, hanno finitura cromata oppure nera e sono rispettivamente abbinati alle basi in alluminio lucido oppure in Nylon di colore nero.

EN

An executive series featuring striking details: slender thicknesses that add elegance, excellent upholstery quality and steel armrests, making it the perfect match for tables and desks with a minimalist design. Although compact, the cushioning ensures outstanding comfort, thanks to the ergonomic design of the single shell. The armrests, made of steel plate, have a chrome or black finish and are paired with polished aluminium or black Nylon bases respectively.

FR

Série direction caractérisée par des détails importants: de fines épaisseurs qui lui confèrent de l'élégance, une excellente qualité du revêtement et des accoudoirs en acier de bonne facture, qui la rendent idéale pour être associée à des tables et à des bureaux au design minimaliste. Le rembourrage, tout en étant compact, offre un excellent confort, grâce à la ligne ergonomique de la monocoque. Les accoudoirs, réalisés en acier plat, ont une finition chromée ou noire et sont respectivement assortis aux piètements en aluminium poli ou en nylon de couleur noire.

D

Chefsesselreihe, die sich durch markante Details auszeichnet: Geringe Stärken, die ihr Eleganz verleihen, eine hervorragende Qualität der Polsterung und Armlehnen aus Stahl, wodurch sie ideal mit Tischen und Schreibtischen von minimalistischem Design kombiniert werden kann. Die Polsterung ist zwar kompakt, bietet aber dank des ergonomischen Designs der Sitzschale einen ausgezeichneten Komfort. Die Armlehnen aus Flachstahl sind verchromt oder schwarz und passen jeweils zu den Fußkreuzen aus poliertem Aluminium oder schwarzem Nylon.



Mod. 21-001U-01
Mec. AX7



Mod. 21-017U
Mec. A19



Mod. 21-008U
Mec. A13



Mod. 21-051U



Mod. 21-002U-01
Mec. AX7

Mod. 21-052U + op. 21-061U







Mod. 21-027U
Mec. A19

Mod. 21-008U + op. A21-70
Mec. A13







TASK

- 054 **X1**
- 068 **Twist**
- 080 **Twist TT**
- 088 **Cobra**
- 098 **Cobra TT**
- 104 **CO2/22**
- 114 **Viva**
- 122 **DattiloGolf 21**



X1

All Mesh / Mid Mesh / All Air

TASK

I

X1 introduce un nuovo concetto di confort per le sedie operative, direzionali e riunioni: l'applicazione dell'imbottitura al sedile in rete portante è innovativa, in quanto unisce l'elasticità della rete alla morbidezza della gomma, rendendo le versioni Mid Mesh e All Air soluzioni uniche e iper-confortevoli. All Mesh, con sedile e schienale in rete autoportante completa la proposta con la sua leggerezza, mantenendo l'alto standard qualitativo e l'affidabilità "made in Italy".

EN

X1 introduces a new concept of comfort for task, executive and meeting chairs, namely the application of load-bearing mesh padding to the seat, an absolute novelty. The application of the padding to the load-bearing mesh seat is innovative, as it combines the elasticity of the mesh with the softness of the foam, making the versions of X1, the Mid Mesh and the All Air, unique and hyper-comfortable. All Mesh version, with seat and backrest in self-supporting mesh, completes the X1 proposal, winning over those who use it with its lightness combined with a high-quality standard and the «made in Italy» reliability.

FR

X1 introduit un nouveau concept de confort pour les sièges opérateurs, de direction et de réunion, à savoir l'application sur l'assise en maille autoportante d'un rembourrage, une nouveauté absolue. L'application du rembourrage sur le siège maille est innovante, car elle combine l'élasticité de la maille avec la douceur de la mousse, rendant les versions X1, Mid Mesh et All Air des solutions uniques et hyper confortables. All Mesh, avec son assise et son dossier en résille autoportante, complète la proposition X1, convainquant ceux qui l'utilisent par sa légèreté allié à un haut standard de qualité et à la fiabilité du "made in Italy".

D

X1 führt ein neues Komfortkonzept für Arbeits-, Konferenzstühle und Chefsessel ein: Die Anbringung der Polsterung an der Sitzfläche aus tragendem Netz ist eine absolute Neuheit. Innovativ ist das Anbringen der Polsterung an der Sitzfläche aus tragendem Netz insofern, weil es die Elastizität der Netzbespannung mit der Weichheit des Schaumstoffs verbindet und somit die X1-Versionen Mid Mesh und All Air besonders komfortabel macht. All Mesh mit Sitzfläche und Rückenlehne aus tragendem Netz vervollständigt die Reihe X1 und überzeugt seine Nutzer mit Leichtigkeit, hohem Qualitätsstandard und Zuverlässigkeit „Made in Italy“.



Mod. X1AM-003U + op. 22BH
Mec. SLYR2



Mod. X1MM-026U + op. 22BH
Mec. PSY6



Mod. X1AA-046U + op. 22BH
Mec. PSY6



Mod. X1AM-W46U
+ op. 22BHW + A22G-18HW/5
Mec. PSY6



Mod. X1MM-032U
Mec. PSY8



Mod. X1AM-004U + 34BH



Mod. X1AM-008U + 34BH + A22G-18H/5



Mod. X1MM-028U + 34BH





Mod. X1MM-024U + 34BH + A22G-18H/5 Mod. X1MM-026U + 22BH





Breathe



Mod. X1AA-046U + 22BH



Mod. X1AA-043U + 34BH



Mod. X1AA-W46U + 22BHW

Mod. X1AA-W47U + 22BHW

X1 | All Air



Mod. X1AA-W43U + 34BHW + A22G-18HW/5 Mod. X1AA-W58U + A22G-18HW/4



Mod. X1AA-W56U



Mod. X1AA-051U + 20BRA



Mod. X1AM-019U + 20BRA



Twist

rete

TASK

I

Serie operativa dal design lineare, Twist si distingue per confort e semplicità d'uso. Dotata di meccanismi funzionali e diversificati in grado di soddisfare le varie esigenze ergonomiche in abbinamento a diversi tipi di braccioli, la serie rappresenta la proposta ideale anche per l'home office: 7 colori di rete, rivestimenti a cartella, struttura bianca o nera, permettono di creare una sedia ad hoc per ogni tipo di necessità.

EN

Task series with a clean design, Twist stands out for its comfort and ease of use. Equipped with functional and diversified mechanisms able to satisfy the various ergonomic needs in combination with different types of armrests, the series is also the ideal proposal for the home office: 7 mesh colors, wide choice of coverings, white or black frame, allow to create a specific chair for every type of need.

FR

Siège de travail au design linéaire, Twist se distingue par son confort et sa facilité d'utilisation. Équipée de mécanismes fonctionnels et diversifiés capables de satisfaire les différents besoins ergonomiques en combinaison avec différents types d'accoudoirs, la série est également la proposition idéale pour le télétravail: 7 couleurs de résille, plusieurs revêtements standard disponibles, structure blanche ou noire, permettent de créer une chaise pour chaque type de besoin.

D

Die Arbeitsstuhlreihe Twist im linearen Design überzeugt durch Komfort und Bedienerfreundlichkeit. Mit unterschiedlichen Funktionsmechaniken ausgestattet, die in Kombination mit mehreren Arten von Armlehnen auf verschiedene ergonomische Bedürfnisse zugeschnitten sind, ist Twist die ideale Lösung auch für das Homeoffice: Mit den 7 Netzfarben, Bezügen nach Stoff-Mustermappe und dem Gestell in weiß oder schwarz lässt sich gezielt ein perfekter Stuhl für jeden Bedarf herstellen.



White TR-W02U + op. 5BHW
Mec. PCS4



White Mod. TR-W07U + op. 22BHW
Mec. SLYR2



Black TR-023U
Mec. SY5



Black TR-002U + op. 22BH
Mec. PCS4



White Mod. TR-W23U + op. 5BHW
Mec. SY5





White Mod. TR-W07U + op. 22BHW
Mec. SLYR2









Black Mod. TR-005U
Mec. PSY6





Black Mod. TR-008U + op. 22BH
Mec. SLYR2



Black Mod. TR-023U + op. 22BH
Mec. SY5





Twist TT

TASK

I

Con un design pulito, morbido e minimale, Twist TT disegna la variante tappezzata di Twist. Leggera ed ergonomica, offre un confort elevato grazie all'imbottitura di schienale e sedile. Lo schienale regolabile con sistema up&down e la possibilità di scelta tra ben 5 meccanismi, rendono Twist TT una sedia operativa versatile e funzionale per le attività lavorative di ogni giorno.

EN

With a clean, soft and minimal design, Twist TT designs the upholstered variant by Twist. Lightweight and ergonomic, it offers high comfort thanks to the padding of the back and seat. The adjustable backrest with up&down system and the possibility of choosing between 5 mechanisms make Twist TT a versatile and functional task chair for activities working every day.

FR

Avec un dessin épuré, doux et minimal, Twist TT conçoit la variante rembourrée par Twist. Léger et ergonomique, il offre un grand confort grâce au rembourrage de dossier et assise. Le dossier réglable avec système up&down et la possibilité de choisir entre 5 mécanismes font de Twist TT une chaise de travail polyvalente et fonctionnelle pour les activités travailler tous les jours.

D

Im Design rein, weich und minimalistisch präsentiert sich Twist TT, die Polstervariante von Twist. Die leichte und ergonomische Gestaltung sowie die Polsterung von Sitz und Rückenlehne sorgen für hohen Sitzkomfort. Die Höhenverstellung der Rückenlehne über Up-&Down-System und gleich 5 Mechaniken zur Auswahl sorgen für Vielseitigkeit und Funktionalität und machen Twist TT zum idealen Stuhl für die täglichen Aufgaben im Büro.



White Mod. TT-W03U
Mec. PCS4



White Mod. TT-W10U
+ op. 22BHW
Mec. SLYR2



Black Mod. TT-009U
+ op. 23BH
Mec. SLYR2







White Mod. TT-W07U + op. 22BHW
Mec. PSY6

White Mod. TT-W09U + op. 5BHW
Mec. SLYR2





Black Mod. TT-001U
Mec. PC



Black Mod. TT-007U + op. 20BRA
Mec. PSY6





Cobra

rete/air

TASK

I

La serie operativa Cobra, dall'alta conformazione ergonomica e dalla linearità inconsueta, si è oggi rinnovata con un nuovo caratteristico supporto lombare 2D che ne riconfigura il design. Proposta in versione RETE e AIR, con struttura nera o bianca (WHITE), Cobra è disponibile in tutti i rivestimenti a cartella, nuove versioni di basi e braccioli regolabili, e tre meccanismi che la rendono versatile e funzionale.

EN

The Cobra task chair series, with a highly ergonomic design and unusual lines, has now been revamped to include a new, distinctive 2D lumbar support that for a reconfigured style. Proposed in the RETE and AIR variants, with a black or white frame, Cobra is available with all standard coverings, new versions with adjustable armrests and bases, and three mechanisms that make it versatile and practical.

FR

La série opérateur Cobra, caractérisée par sa conformation ergonomique accentuée et une linéarité inhabituelle, est perfectionnée aujourd'hui avec un nouveau support lombaire 2D qui en redéfinit le design. Proposée dans la version RETE et AIR, avec structure noire ou blanche, Cobra est disponible dans tous les revêtements du nuancier, avec de nouvelles versions de piètements et accoudoirs réglables, et trois mécanismes qui la rendent polyvalente et fonctionnelle.

D

Die Cobra Arbeitsstuhlreihe mit ergonomischer Gestaltung und außergewöhnlicher Linienführung besitzt ab sofort eine charakteristische Lendenwirbelstütze 2D, die das Design neu definiert. Cobra ist erhältlich in den Versionen RETE und AIR mit schwarzem oder weißem Gestell, allen Bezügen nach Stoff-Mustermappe, neuen Gestellausführungen, verstellbaren Armlehnen sowie drei Mechaniken, die für Vielseitigkeit und Funktionalität sorgen.



RETE White
Mod. CB-W05U-22
+ op. 22BHW + op. CB-ADHW-2D
Mec. SLYR2



RETE Black
Mod. CB-005U-22
+ op. 15BH-PU
Mec. SLYR2



AIR White
Mod. CB-W36U-22
+ op. 22BHW + op. CB-ADHW-2D
Mec. SLYR2



AIR Black
Mod. CB-031U-22
+ op. 14BH
Mec. PCS4



RETE Black
Mod. CB-011U-22
+ op. CB-KIT/EL
Mec. PCS4







RETE Black Mod. CB-005U-22 + op. 22BH+ op. CB-ADH-2D
Mec. SLYR2



RETE Black Mod. CB-011U-22 + op. 5BH
Mec. PCS4



RETE Black Mod. CB-015U-22 + op. 22BH+ op. CB-ADH-2D
Mec. SLYR2



AIR White Mod. CB-W25U-22 + op. 13BHW
Mec. SLYR2

AIR White Mod. CB-W31U-22 + op. 13BHW
Mec. PCS4



AIR White Mod. CB-W26U-22 + op. 22BHW + op. CB-ADHW-2D
Mec. SLYR2



AIR Black Mod. CB-026U-22 + op. 22BH + op. CB-ADH-2D
Mec. SLYR2

AIR Black Mod. CB-031U-22 + op. 14BH
Mec. PCS4



AIR Black Mod. CB-036U-22 + op. 14BH
Mec. SLR2



Cobra TT

TASK

I

Cobra TT si distingue per l'alto confort, grazie soprattutto alla conformazione ergonomica dello schienale, che permette all'operatore di essere a diretto contatto con il sostegno lombare, favorendo una postura corretta.

La serie è proposta con schienale regolabile in altezza, con o senza poggiatesta. La disponibilità di cinque modelli di braccioli (di cui 4 regolabili) e di tre meccanismi li rendono versatile, funzionale e adatta ad ogni tipo di esigenza.

EN

Cobra TT stands out due to the extra comfortable seat whose ergonomic configuration of the backrest enables the operator to be in direct contact with the lumbar support, fostering correct posture.

The series is available with height adjustable backrest, with or without headrest. Its five armrest models (4 of which are adjustable) and three mechanisms, make Cobra TT versatile, functional and suitable for all needs.

FR

Cobra TT se distingue par le grand confort de son siège qui, grâce avant tout à la conformation ergonomique du dossier, permet à l'opérateur d'être en contact direct avec l'appui lombaire, ce qui favorise une position correcte.

La série est proposée avec dossier réglable en hauteur, avec ou sans tête.

La structure est de couleur noire. La disponibilité de cinq modèles d'accoudoirs (dont 4 réglables) et de trois mécanismes rendent le fauteuil polyvalent, fonctionnel et adapté à tous les besoins.

D

Cobra TT zeichnet sich durch hohen Sitzkomfort aus, der - vor allem durch die ergonomische Gestaltung der Rückenlehne - dem Nutzer einen direkten Kontakt mit der Lendenwirbelsäule ermöglicht und somit eine korrekte Sitzhaltung unterstützt.

Die Reihe ist mit höhenverstellbarer Rückenlehne mit und ohne Kopfstütze erhältlich. Das Gestell ist schwarz. Die Verfügbarkeit von fünf Armlehnenmodellen (vier davon verstellbar) und drei Mechanismen machen ihn vielseitig, funktionell und für jeden Bedarf geeignet.



Mod. CT-003U-22 + op. 14BH
Mec. SLY4



Mod. CT-015U-22 + op. 22BH
Mec. SLYR2



Mod. CT-013U-22 + op. CB-KIT/EL
Mec. SLY4



Mod. CT-015U-22 + op. 22BH
Mec. SLR2





Mod. CT-004U-22 + op. 14BH
Mec. SLY4

Mod. CT-015U-22 + op. 22BH
Mec. SLYR2



Mod. CT-015U-22 + op. 5BH
Mec. SLYR2

Mod. CT-013U-22 + op. CB-KIT/EL
Mec. SLY4



CO2/22

rete/air

TASK

I

Pragmatica e concreta, la serie CO2/22 rappresenta un «classico» rinnovato molto confortevole, completo nelle funzioni e regolazioni. Il sedile è ampio e accogliente, lo schienale – rete o air – di taglia alta, è dotato di fascia lombare regolabile in altezza.

Grazie alla sua ergonomia e alle caratteristiche prestazionali, dal punto di vista del confort, la serie si posiziona al top della proposta Task di Uni Collection.

EN

The practical and distinctive CO2/22 series is a very comfortable, revamped «classic», with comprehensive functions and adjustments. The seat is wide and relaxing, the high back – RETE or air – is fitted with a height-adjustable lumbar band. The ergonomics and performance characteristics of the series put it at the top of the Uni Collection Task range when it comes to comfort.

FR

Pragmatique et concrète, la série CO2/22 renouvelle un «classique» en créant une version très confortable et complète dans ses fonctions et ses réglages. L'assise est large et accueillante, le dossier haut – RETE ou air – est muni d'un support lombaire réglable en hauteur. Grâce à son ergonomie et à ses performances, du point de vue du confort, la série se positionne au sommet de la proposition Task de l'Uni Collection.

D

Pragmatisch und konkret, ist die Reihe CO2/22 ein «Klassiker» mit Neuerungen, äußerst komfortabel, mit vielen Funktionen und Einstellungen. Der Sitz ist gut geformt und bequem, die Rückenlehne - in den Ausführungen RETE oder AIR erhältlich - ist hoch und mit höhenverstellbarer Lendenwirbelstütze ausgestattet. Dank ergonomischer Gestaltung und vielen Leistungsmerkmalen positioniert sich die Reihe in Sachen Komfort an der Spitze der Palette Task von Uni Collection.



RETE Mod. C22-352U + op. 8BRA



AIR Mod. C22-366U + op. 24BH

















Mod. C22-366U + op. 24BH Mod. C22-367U + op. 24BH



Viva

rete/air

TASK

I

Lineare, sobria e confortevole. Proposta in versione RETE, con una scelta di 7 colori o in versione AIR, in tutti i rivestimenti a cartella. Imbottitura del sedile «Long-Life» con 3 strati di gomma a densità differenziata. La serie Viva è composta da una sedia operativa proposta con tre meccanismi, con o senza braccioli, e da una sedia ospiti, disponibile con base a slitta dotata di braccioli integrati.

EN

Sleek, discreet and comfortable. Proposed in the RETE version, with a choice of seven colours, and the AIR version, in all listed coverings. «Long-Life» seat padding with 3 layers of different density rubber. The Viva series consists of a task chair that comes with three mechanisms, with or without armrests; and a visitor chair, available with sled base and integrated armrests.

FR

Linéaire, sobre et confortable. Proposée dans la version RETE, avec un choix de 7 couleurs ou dans la version AIR, dans tous les revêtements du nuancier. Rembourrage de l'assise «Long-Life» avec 3 couches de mousse de densité variable. La série Viva est composée d'une chaise opérateur proposée avec trois mécanismes, avec ou sans accoudoirs, et d'une chaise visiteur, disponible avec piètement luge muni d'accoudoirs intégrés.

D

Linear, schlicht und komfortabel. In den Ausführungen RETE mit Netzbespannung in 7 Farben und AIR mit allen Bezügen nach Stoff-Mustermappe erhältlich. Sitzpolsterung «Long-Life» mit 3 Schaumstoffschichten unterschiedlicher Dichte. Die Reihe Viva besteht aus einem Arbeitsstuhl mit drei Mechaniken, mit und ohne Armlehnen sowie einem Besucherstuhl mit Armlehnen, der nur als Freischwinger erhältlich ist.



AIR Mod. VV-132U
Mec. PCS4



RETE Mod. VV-102U + op. 15BH-PU
Mec. SLYR2



AIR VV-152U



RETE VV-011U



RETE Mod. VV-001U + op. 11BH
Mec. PCS4

RETE Mod. VV-021U
Mec. SLY4



RETE Mod. WV-102U + op. 15BH-PU
Mec. SLYR2





AIR Mod. VV-132U
Mec. PCS4

AIR Mod. VV-141U + op. 10BH
Mec. SLY4







DattiloGolf 21

basic/plus

TASK

I

Serie «entry level» che rappresenta la proposta di sedie operative per videoterminalista e smart worker, ed è considerata un prodotto di elevato standard qualitativo, con un buon rapporto qualità/prezzo. La nuova Dattilo Golf 21 nella versione BASIC, introduce un miglioramento tecnico-qualitativo, e attraverso l'integrazione di PLUS, un ulteriore upgrade, grazie all'imbottitura più consistente con gomma ignifuga morbida e reattiva. La proposta si completa con l'inserimento dello schienale regolabile con sistema up&down e la possibilità di scelta tra ben 3 meccanismi.

EN

Entry level series representing the range of task chairs for video and smart workers, this is regarded as a high quality product with a good quality/price ratio. The BASIC version of the new Dattilo Golf 21 introduces a technical and quality improvement, which can be upgraded by integrating PLUS, with soft, responsive, more substantial fire-retardant rubber padding. The proposal is completed with the incorporation of an adjustable backrest with the up&down system and a choice of no less than 3 mechanisms.

FR

Série «entrée de gamme» qui représente la proposition de chaises pour opérateurs sur écran et télétravailleurs, et est considérée comme un produit de haut niveau qualitatif, avec un bon rapport qualité/prix. La nouvelle chaise Dattilo Golf 21, dans la version BASIC, introduit une amélioration technico-qualitative, et avec l'intégration de PLUS, un atout supplémentaire, grâce à un rembourrage plus important avec une mousse ignifuge souple et réactive. La proposition est complétée par l'insertion du dossier réglable avec système up&down et la possibilité de choix entre 3 mécanismes.

D

«Entry Level»-Reihe, die das Angebot von Arbeitsstühlen für Bildschirmarbeiter/innen und Smartworker darstellt und als qualitativ hochwertiges Produkt mit einem guten Preis-Qualitäts-Verhältnis gilt. Der neue Dattilo Golf 21 in der BASIC-Version bietet eine technische und qualitative Verbesserung und durch die Integration von PLUS eine weitere Optimierung dank einer stärkeren Polsterung aus weichem, reaktionsfreudigem feuerfestem Schaumstoff. Vervollständigt wird das Angebot durch die verstellbare Rückenlehne mit Up&Down-System und einer Auswahl von 3 Mechanismen.



PLUS Mod. DG21-07U
+ op. 14BH
Mec. SLY4



PLUS Mod. DG21-14U
+ op. 6BRA
Mec. PCS4



BASIC Mod. DG21-32U
Mec. PC



BASIC Mod. DG21-44U
+ op. 8BH
Mec. PCS4



BASIC Mod. DG21-54U + op. 8BH
Mec. PCS4



BASIC Mod. DG21-34U + op. 15BH-PU
Mec. PCS4



BASIC Mod. DG21-36U
Mec. SLY4



BASIC Mod. DG21-42U
Mec. PC

BASIC Mod. DG21-54U + op. 8BH
Mec. PCS4



PLUS Mod. DG21-14U + op. 6BRA
Mec. PCS4

PLUS Mod. DG21-21U
Mec. PC





VISITORS/ CONFERENCE

130 1000 Plus
148 1000 Revo
164 Jx



1000 Plus

VISITORS/
CONFERENCE

I

Lineare e moderna, 1000 Plus ha raccolto le peculiarità di 1000 Revo reinterpretandone il design in chiave più accattivante, grazie anche ad una selezione di colori di tendenza. Versatile e agile per i momenti di condivisione lavorativa, dotata di un'ottima impilabilità, è proposta anche in versione sgabello e panca modulare per l'attesa.

EN

With a modern and clean design, 1000 Plus series has collected the peculiarities of 1000 Revo by reinterpreting them in a more captivating design, thanks also to the choice of a selection of colors of trend. Versatile and agile for moments of work sharing, equipped with an excellent stackability, it is also available in a stool and modular bench version for waiting areas.

FR

Linéaire et moderne, 1000 Plus a capté les particularités de 1000 Revo en les réinterprétant le design dans une touche plus captivante, avec des lignes douces et une sélection de couleurs de tendance. Polyvalent et agile pour les moments de travail partagé, doté d'un excellent empilage, il se décline également en version tabouret et banquette modulable pour l'attente.

D

Linear und modern, alle Besonderheiten von 1000 Revo gibt es nun auch bei 1000 Plus in einem noch ansprechenderen Design und schönen Trendfarben. Vielseitig und gewandt für gemeinsames Arbeiten, gut stapelbar und auch als Hocker und Traversenbank für den Wartebereich erhältlich.



Mod. PL1-010U



Mod. PL1-008U



Mod. PL1-048U



Mod. PL1-026U



Mod. PL1-056U + op PL-101U







Mod. PL1-008U + op. PL1-101U







Mod. PL1-104U



Mod. PL1-102U











Mod. PL1-052U



Mod. PL1-056U + op. PL1-101U







Mod. PL1-066U Mod. PL1-066U + op. PL1-115U



1000 Revo

pp/rete/im

VISITORS/
CONFERENCE

I

La serie 1000 Revo in versione IM (imbottita) oggi si arricchisce con l'inserimento delle versioni RETE (sedile imbottito e schienale rete) e PP (sedile/schienale in Polipropilene) mantenendo invariata la completezza di gamma. Conosciuta sia per la leggerezza estetica che per robustezza e praticità, grazie alla buona impilabilità, la serie si presta all'utilizzo in circostanze molteplici: da aree conferenza e formazione, a sale per l'attesa, fino a diventare protagonista attorno al tavolo in sale riunione o ufficio.

EN

1000 Revo in IM (padded) version has now been expanded to include the RETE (padded seat/mesh backrest) and PP (Polypropylene seat/backrest) versions, while preserving the comprehensive range. Known for being light aesthetically as well as robust and practical, its good stacking capability makes the range perfect for multiple situations, including conference and training areas, and waiting rooms, through to being a major player at tables in meeting rooms or offices.

FR

1000 Revo dans la version IM (rembourrée) s'enrichit aujourd'hui avec l'insertion des versions RETE (assise rembourrée/dossier résille) et PP (assise/dossier en polypropylène), tout en conservant l'exhaustivité de la gamme. Renommée tant pour sa légèreté esthétique que pour sa robustesse et sa praticité, grâce à sa bonne empilabilité, la série se prête à une utilisation dans de nombreuses circonstances: des salles de conférence et de formation, aux salles d'attente, jusqu'à devenir une protagoniste autour de la table dans les salles de réunion ou les bureaux.

D

1000 Revo in der Version IM (gepolstert) erweitert sich mit den Versionen RETE (gepolsterter Sitz/Rückenlehne aus Netz) und PP (Sitz/Rückenlehne aus Polypropylen), wobei die Vollständigkeit der Produktpalette erhalten bleibt. Die Serie ist bekannt für ihre ästhetische Leichtigkeit, ihre Robustheit und ihre praktische Anwendbarkeit dank ihrer guten Stapelbarkeit. Sie eignet sich daher für vielfältige Einsatzmöglichkeiten: von Konferenz- und Schulungsräumen über Wartezimmer bis hin zum Protagonisten am Tisch in Besprechungsräumen oder Büros.



PP Mod. R1-076U



PP Mod. R1-271U



RETE Mod. R1-126U



IM Mod. R1-031U



PP Mod. R1-292U























op. R1-054U

Gancio lungo a scomparsa, sedia con braccioli o con braccioli e scrittoio | Long concealed hook, chair with arms or with arms and writing tablet |
Accroche longue escamotable, chaise avec accoudoirs ou avec accoudoirs et tablette écriteire | Langer umklappbarer Reihenverbinder, Stuhl mit
Armlehnen oder mit Armlehnen und Schreibplatte









Jx

rete/air

VISITORS/
CONFERENCE

I

Rigorosa ed essenziale la serie JX si evolve proponendosi come una valida alternativa tra le sedute ospiti, fronte scrivania e per riunioni, ed anche per zone d'attesa. Le due varianti RETE (ora con rete tipo N) e AIR (con membrana) ben si accompagnano alle operative presenti a catalogo. Disponibile nelle versioni a quattro gambe o su slitta, con o senza braccioli.

EN

Clean and simple, the JX series has evolved to become a viable alternative for visitor and desk seating as well as for meeting and waiting areas. The two variants, RETE (now with N-type mesh) and AIR (with membrane) go well with the listed task chairs. Available in 4-leg or sled versions, with or without armrests.

FR

Rigoureuse et essentielle, la série JX évolue en se proposant comme une alternative valable parmi les chaises visiteurs, réception et réunions, ainsi que pour les zones d'attente. Les deux variantes RETE (maintenant avec résille type N) et AIR (avec membrane) s'accordent bien avec les modèles opérateur en catalogue. Disponible dans les versions à quatre pieds ou sur piètement luge, avec ou sans accoudoirs.

D

Die strenge und nüchterne Reihe JX hat sich zu einer echten Alternative unter den Besucher- und Konferenzstühlen und auch für Wartebereiche entwickelt. Die zwei Varianten RETE (jetzt mit Netzbespannung Typ N) und AIR (mit Membran) passen gut zu den Arbeitsstühlen aus dem Katalog. Erhältlich in den Versionen mit vier Beinen oder mit Kufengestell, mit oder ohne Armlehnen.



RETE-PP Mod. JX-071U



AIR Mod. JX-057U











AIR-PP Mod. JX-097U











LOUNGE/ WAITING

- 176 **Così**
- 192 **Gemma**
- 200 **Dolly**
- 208 **Ken**
- 220 **Boy**
- 226 **Mito**
- 232 **Tago**
- 238 **Quadro**



Così

LOUNGE/
WAITING

I

COSÌ si aggiorna. Alla versione standard – con scocca tutta in Polipropilene – si aggiunge la nuova versione IM con scocca completamente rivestita, disponibile in tutti i rivestimenti a cartella. La proposta inoltre si amplia, con l'inserimento di strutture fisse in metallo e girevoli, anche con base spider girevole in legno.

EN

COSÌ updates. To the standard version, with the shell entirely in Polypropylene, the new IM version is now added with a fully upholstered body, available with all the coverings of our cards. In addition to this, the proposal of frames is expanded, so beside the fixed metal and swivel ones, also a swivel wooden spider base is also available.

FR

COSÌ se met à jour. A la version standard, avec coque entièrement en Polypropylène se rajoute la nouvelle version IM, coque entièrement revêtue, disponible avec tous les revêtements dans nos nuanciers. En plus, la proposition des structures est élargie, avec l'inclusion de structures métalliques fixes et pivotantes, également avec piétement pyramidal en bois.

D

COSÌ geht mit der Zeit. Zur Standardversion – mit Sitzschale ganz aus Polypropylen – kommt die neue, vollständig bezogene Ausführung IM, erhältlich mit allen Bezügen nach Stoff-Mustermappe. Erweitert wird das Angebot zudem mit festen Gestellen aus Metall sowie drehbaren Ausführungen, auch mit Sternfuß aus Holz.



IM Mod. CSI-077U



PP Mod. CS-026U









IM Mod. CSI-068U











IM Mod. CSI-082U Libreria | Bookcase | Bibliothèque | Bücherregal **Blog Concept**









IM Mod. CSI-098U





Gemma

LOUNGE/
WAITING

I

Proposta con monoscocca in Polipropilene in 3 colori, con braccioli integrati, caratterizzata dallo schienale microforato.

Il sedile imbottito fissato alla scocca e le varie tipologie di struttura completano la proposta della serie.

Il cuscino del sedile può essere tappezzato con ogni rivestimento a cartella.

EN

Comes with Polypropylene single shell in 3 colours, with integrated armrests, featuring micro-perforated backrest.

The padded seat attached to the shell and the varied range of structures complete the series proposal.

The seat cushion can be upholstered with any of the listed coverings.

FR

Petit fauteuil avec monocoque en polypropylène en 3 couleurs, accoudoirs intégrés, et caractérisé par le dossier microperforé.

L'assise rembourrée fixée à la coque et les différents types de structure complètent la proposition de la série. Le coussin de l'assise peut être tapissé avec tous les revêtements du nuancier.

D

Angeboten mit Sitzschale aus Polypropylen in 3 Farben, mit integrierten Armlehnen und einer mikro-perforierten Rückenlehne. Der gepolsterte Sitz, der an der Schale befestigt ist, und die verschiedenen Arten von Gestellen vervollständigen die Reihe. Das Sitzkissen kann mit allen Bezügen nach Stoff-Mustermappe bezogen werden.



Mod. GE-031U



Mod. GE-003U



Mod. GE-007U



Mod. GE-017U















Dolly

LOUNGE/
WAITING

I

La serie si amplia integrando alla classica poltroncina su slitta nuove versioni girevoli: spider in Nylon, spider in alluminio e 5 razze.

Si completa dunque il ventaglio di proposte di questa poltroncina «classica» ideale per l'attesa, per ospiti o riunioni.

Avendo sedile e schienale separati può essere presentata con rivestimenti diversi per aumentarne l'appeal.

EN

The series has been expanded by integrating new swivel versions to the classic sled base chair: Nylon spider, aluminium spider and 5-star.

This completes the range of proposals for this «classic» chair, perfect for waiting areas, visitors or meetings.

Since the seat and backrest are separate, it can be upholstered with different covers to heighten its appeal.

FR

La série s'agrandit en ajoutant au classique petit fauteuil sur piètement luge de nouvelles versions pivotantes: piètement «spider» en nylon, «spider» en aluminium et 5 branches.

La gamme de propositions de ce fauteuil «classique», idéal pour l'attente, les visiteurs ou les réunions, est ainsi complétée.

L'assise et le dossier étant séparé, il est possible de les réaliser dans des revêtements différents pour en augmenter l'attrait.

D

Die Reihe erweitert sich um neue, drehbare Varianten des klassischen Freischwinger-Sessels: Sternfuß aus Nylon, Sternfuß aus Aluminium und 5-Stern-Fußkreuz. Dies vervollständigt die Auswahl an Angeboten für diesen «klassischen» Sessel, der ideal für Wartebereiche, Besucher oder Meetings ist. Da die Sitzfläche von der Rückenlehne getrennt ist, können verschiedene Bezüge verwendet werden, um seine Attraktivität zu steigern.



Mod. DY-021U



Mod. DY-017U



Mod. DY-027U



Mod. DY-001U















Ken

LOUNGE/
WAITING

I

COSÌ si aggiorna. Alla versione standard – con scocca tutta in Polipropilene – si aggiunge la nuova versione IM con scocca completamente rivestita, disponibile in tutti i rivestimenti a cartella. La proposta inoltre si amplia, con l'inserimento di strutture fisse in metallo e girevoli, anche con base spider girevole in legno.

EN

COSÌ updates. To the standard version, with the shell entirely in Polypropylene, the new IM version is now added with a fully upholstered body, available with all the coverings of our cards. In addition to this, the proposal of frames is expanded, so beside the fixed metal and swivel ones, also a swivel wooden spider base is also available.

FR

COSÌ se met à jour. A la version standard, avec coque entièrement en Polypropylène se rajoute la nouvelle version IM, coque entièrement revêtue, disponible avec tous les revêtements dans nos nuanciers. En plus, la proposition des structures est élargie, avec l'inclusion de structures métalliques fixes et pivotantes, également avec piétement pyramidal en bois.

D

COSÌ geht mit der Zeit. Zur Standardversion – mit Sitzschale ganz aus Polypropylen – kommt die neue, vollständig bezogene Ausführung IM, erhältlich mit allen Bezügen nach Stoff-Mustermappe. Erweitert wird das Angebot zudem mit festen Gestellen aus Metall sowie drehbaren Ausführungen, auch mit Sternfuß aus Holz.



Mod. KEN-001U



Mod. KEN-002U



Mod. KEN-003U



Mod. KEN-001U



Mod. x7 KEN-001U Tavolo | Table | Table | Tisch Mod. TA-108



Mod. KEN-001U

Mod. x4 KEN-001U









outdoor use





Mod. x4 KEN-003U Tavoli a colonna | Column tables | Tableaux à colonnes | Säulentische





Boy

LOUNGE/
WAITING

I

Sgabelli bassi e alti con un design accattivante, valorizzato dalle gambe in legno massello di faggio e dalla possibilità di rivestire il sedile in ogni rivestimento a cartella. Le parti plastiche sono proposte in colore antracite e bianco. Gli sgabelli Boy si abbinano perfettamente ai tavoli bassi e alti della serie di tavoli presenti nel catalogo Design di Sesta.

EN

High and low stools with an attractive design, set off by the solid beech legs and the possibility of upholstering the seat in any of the listed coverings. The plastic parts are available in anthracite and white. The Boy stools are a perfect complement for the range of high and low tables in the Sesta Design catalogue.

FR

Tabourets bas et hauts avec un design attrayant, mis en valeur par les pieds en hêtre massif et la possibilité de recouvrir l'assise avec n'importe quel revêtement du nuancier. Les parties en plastique sont proposées en anthracite et blanc. Les tabourets Boy s'accordent parfaitement avec les tables basses et hautes de la gamme de tables présentes dans le catalogue Design de Sesta.

D

Niedrige und hohe Hocker mit attraktivem Design, aufgewertet durch massive Buchenholzbeine und die Möglichkeit, die Sitzfläche mit allen Bezügen nach Stoff-Mustermappe zu beziehen. Die Kunststoffteile werden in den Farben Anthrazit und Weiß angeboten. Boy passt perfekt zu den niedrigen und hohen Tischen aus dem Sesta Design Katalog.



Mod. BY-002U



Mod. BY-006U





Mod. BY-002U Mod. BY-001U





Mod. BY-007U

Mod. BY-006U



Mito

LOUNGE/
WAITING

I

Poltrona e divani a 2 e 3 posti, panche e tavolini completano gli elementi di una serie dal disegno lineare e minimalista, dove tutti gli elementi sono racchiusi all'interno delle linee di tappezzeria.

Tutti gli elementi condividono la stessa tipologia di piedino in acciaio proposto in 3 finiture: cromata (CR), oppure con finitura nera (N) o bianca (BI).

EN

Easy chair and 2 and 3-seater sofas, benches and coffee tables complete the items in a series with a linear and minimalist design, where each piece is enclosed inside the upholstery lines.

All the items in the series share the same type of steel feet, in 3 finishes: chrome (CR, black (N) or white (BI).

FR

Un fauteuil et des canapés 2 et 3 places, des banquettes et des tables basses complètent les pièces d'une série au design linéaire et minimaliste, où tous les volumes sont contenus dans les lignes du revêtement.

Tous les éléments partagent le même type de pied en acier proposé en 3 finitions: chromée (CR), noire (N) ou blanche (BI).

D

Sessel, Zwei- und Dreisitzer-sofas, Bänke und Beistelltische vervollständigen die Elemente einer Reihe von linearem und minimalistischem Design, bei der alle Elemente von den Linien der Polsterung umschlossen werden.

Alle Elemente haben den gleichen Stahlfuß, der in 3 Ausführungen erhältlich ist: verchromt (CR), schwarz (N) oder weiß (BI).



Mod. MY-036U



Mod. MY-026U



Mod. MY-046U



Mod. MY-016U



Mod. MY-002U + op. MY-072U Mod. MY-003U + op. MY-073U 2x Mod. MY-001U







1. Mod. MY-002U + op. MY-072U 2. Mod. MY-MY-011 3. MY-015U 4. MY-001U 5. MY-016U



Tago

LOUNGE/
WAITING

I

Tago rappresenta il «classico» divano da l'attesa per l'ufficio. Serie composta da poltrona e divani a 2 e 3 posti e tavolini in vetro. Poltrone e divani sono proposti con 4 piedi realizzati in acciaio proposto in 3 finiture: cromata (CR), oppure con finitura nera (N) o bianca (BI).

EN

Tago epitomises the «classic» sofa for the office waiting area. The series consists of chair and 2- and 3-seater sofas and glass coffee tables. Easy chairs and sofas come with 4 steel feet, in 3 finishes: chrome (CR), black (N) or white (BI).

FR

Tago représente le modèle «classique» de canapé d'attente pour le bureau. La série est composée d'un fauteuil, de canapés 2 et 3 places et de tables basses en verre. Les fauteuils et les canapés sont proposés avec 4 pieds réalisés en acier en 3 finitions: chromée (CR), noire (N) ou blanche (BI).

D

Tago ist das «klassische» Bürossofa. Die Reihe besteht aus Sesseln, Zwei- und Dreisitzer-sofas sowie Beistelltischen aus Glas. Sessel und Sofas werden mit 4 Stahlfüßen angeboten, die in 3 Ausführungen erhältlich sind: verchromt (CR), schwarz (N) oder weiß (BI).



Mod.TG-003U + op. 2x BG-134



Mod.TG-002U



Mod.TG-015U



Mod.TG-009U



1.

2.



1. Mod. TG-001U 2. Mod. TG-009U 3. Mod. TG-003U + op. 2x BG-134 4. Mod. TG-007U



Mod.TG-002U + op. BG-134





Quadro

LOUNGE/
WAITING

I

Volutamente concepita con dimensioni ridotte rispetto ai divani classici, la serie Quadro, composta da poltrona e divano a 2 posti, è ideale per ambienti con spazi contenuti. Poltrona e divano sono dotati di 4 piedini in alluminio pressofuso, finitura satinata.

EN

Specifically designed to be smaller than traditional sofas, the Quadro series - consisting of easy chair and 2-seater sofa - is perfect for small spaces. Easy chair and sofa are fitted with 4, die-cast aluminium feet, with satin finish.

FR

Dessinée délibérément avec des dimensions réduites par rapport aux canapés classiques, la série Quadro, composée d'un fauteuil et d'un canapé 2 places, est idéale pour les espaces restreints. Le fauteuil et le canapé sont munis de 4 pieds en aluminium moulé sous pression, finition satinée.

D

Die Reihe Quadro, die aus einem Sessel und einem Zweisitzersofa besteht, anders als die klassischen Sofas wurde sie mit kompakten Abmessungen konzipiert und ist bestens für kleine Räume geeignet. Die 4 Füße sind aus satiniertem Aluminiumdruckguss.



Mod. QD-002U + op. BG-134



Mod. QD-001U





Le illustrazioni hanno solo valore indicativo. La proprietà, la realizzazione e riproduzione delle caratteristiche estetiche e costruttive qui illustrate sono riservate a termini di legge. I colori hanno valore indicativo in quanto soggetti alle tolleranze dei processi di stampa.

These pictures have only an approximate value. The property, the realization and the reproduction of the aesthetic and constructive characteristics, here illustrated, are reserved by law. Colours are indicative as they are subject to the alterations of the printing process.

Ces illustrations sont seulement indicatives. La propriété, la réalisation et la reproduction des caractéristiques esthétiques et de construction ci-illustrées sont réservées selon la loi. Les coloris sont seulement indicatifs dès qu'ils peuvent subir des modifications de ton pendant le processus d'imprimerie.

Die Abbildungen in diesem Katalog sind indikativ. Das geistige Eigentum, die Fertigung und Reproduktion der abgebildeten Produkte ist gesetzlich geschützt. Die abgebildeten Farben der Produkte sind durch den Druck indikativ und können von der Realität abweichen.



INFORMAZIONI TECNICHE

TECHNICAL INFORMATIONS
INFORMATIONS TECHNIQUES
TECHNISCHE INFORMATIONEN





EXECUTIVE

CHIC



Tests EN 1335
EN 1335 tests
Tests norme EN 1335
Prüfungen nach EN 1335



1/IM = Disponibile per alcuni rivestimenti a cartella
Available for some covering only
À disposition que pour quelque revêtement
Erhältlich für einige Bezüge nach Stoff-Mustermappe

Serie direzionale realizzata con monoscocca in faggio multistrati proposta in tre dimensioni: alta con poggiatesta integrato, alta (circa 20 cm in meno) e bassa. Schienale completamente imbottito sul retro dello schienale, mentre su tutto il fronte è applicato un cuscino imbottito a fasce orizzontali con materassini di sofficie Dacron; sul sedile è applicato uno strato di gomma indeformabile da 3 cm. Braccioli a sbalzo, realizzati in alluminio, in finitura lucida, in colore bianco (RAL 9016) o nero, disponibili con pad tappezzato.
Versione direzionale con meccanismo oscillante a fulcro centrale A19 o a fulcro avanzato TX36.
Base Ø 70 cm in alluminio finitura lucida o Ø 68 cm Nylon in colore nero o bianco.
Versione ospiti girevole, con schienale alto e basso, disponibile con base Spider a quattro razze, in alluminio finitura lucida (LU) o in Nylon, colore bianco o nero, con piedini o ruote.

Executive series comes with a beech plywood single shell in three sizes: high with integrated headrest, high (about 20 cm lower) and low. The rear of the backrest is fully upholstered, while a cushion padded with horizontal bands of soft Dacron pads is attached to the whole front; the seat comes with a non-deformable, 3-cm thick layer of rubber. Cantilever armrests made of aluminium, with a polished finish, in white (RAL 9016) or black, available with upholstered pad.
Executive version with central tilt mechanism (A19) or knee-tilt mechanism (TX36).
Base in polished aluminium (Ø 70 cm) or in black or white Nylon (Ø 68 cm).
Swivel visitor version, with high or low backrest, available with 4-star spider base, in polished aluminium (LU) finish or in black or white Nylon, with glides or castors.

Série de direction réalisée avec mono-coque en multiples de hêtre proposée en trois hauteurs: haute avec appuie-tête intégré, haute (environ 20 cm en moins) et basse. Le dossier est entièrement rembourré sur la face arrière, tandis qu'un coussin rembourré à bandes horizontales avec couches en Dacron moelleux est appliquée sur toute la face avant; une couche de caoutchouc indéformable de 3 cm est appliquée sur l'assise. Accoudoirs cantilever, réalisés en aluminium, finition polie, en blanc (RAL 9016) ou en noir, disponible avec manchette rembourrée.
Version direction avec mécanisme basculant à axe central A19 ou à axe déporté TX36.
Piètement Ø 70 cm en aluminium finition polie ou Ø 68 cm en Nylon noir ou blanc.
Version visiteur pivotante, avec dossier haut et bas, disponible avec piètement « spider » à quatre branches, en aluminium finition polie (LU) ou en Nylon, blanc ou en noir, avec patins ou roulettes.

Chefsesselreihe mit Sitzschale aus Buchenschicht-holz in drei Größen: hoch mit integrierter Kopf-stütze, hoch (ca. 20 cm niedriger) und niedrig. Die Rückenlehne ist hinten vollständig gepolstert, während die gesamte Vorderseite mit einem horizontal abgesteppten Kissen mit weichen Dacron-Einlagen gepolstert ist. Die Sitzfläche ist mit einer 3 cm dicken Schicht aus nicht verformbarem Schaum versehen. Freitragende Armlehnen aus Aluminium in poliert, weiß (RAL 9016) oder schwarz, verkrigbar mit gestoffeerd kussen.
Ausführung Chefsessel mit Wippmechanik A19 (mit zentralem Drehpunkt) oder TX36 (mit vorge-setztem Drehpunkt).
Fußkreuz Ø 70 cm aus poliertem Aluminium oder Ø 68 cm aus Nylon in schwarz bzw. weiß.
Ausführung Besucherdrehstuhl mit hoher und niedriger Rückenlehne, erhältlich mit 4-Stern-Fuß-kreuz aus poliertem Aluminium (LU) oder Nylon, in weiß oder schwarz, mit Gleitern oder Rollen.

Base | Base | Piètement | Fußkreuz

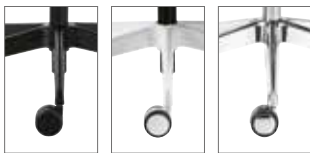

NY - Ø 68 BI - Ø 68 LU - Ø 70

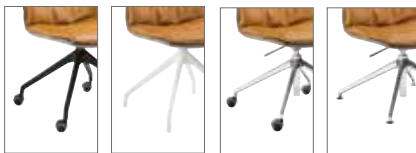

NYN - Ø 67 NYBI - Ø 67 LU - Ø 70

Braccioli | Armrests | Accoudoirs | Armlehnen



BRA01-N BRA01-LU BRA01-BI



Op. CC01-BPI

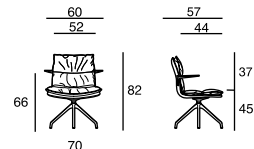
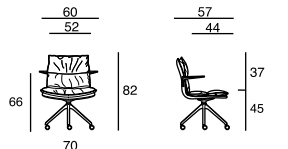
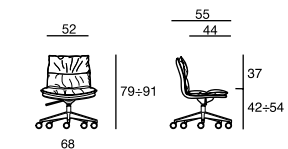
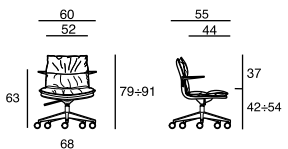
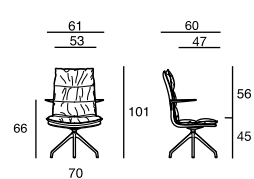
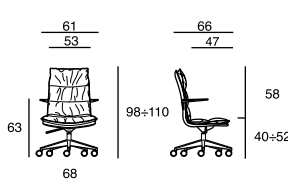
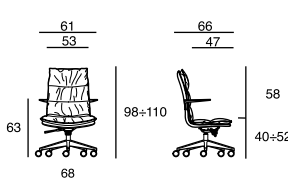
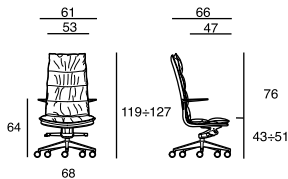

EXECUTIVE

MY MESH

 Tests EN 1335
 EN 1335 tests
 Tests norme EN 1335
 Prüfungen nach EN 1335

Serie direzionale completamente in rete autoportante (Poliestere/Polielastomero), proposta in versione Black (struttura nera/rete nera) o in versione White (struttura bianca RAL 9003/rete colore grigio chiaro o nero).

Le poltrone sono disponibili in due altezze, schienale alto con poggiatesta integrato con base girevole a 5 razze oppure con schienale medio, disponibile con base girevole a 5 razze con base Spider (a 4 razze con piedini, sedile non elevabile). Braccioli fissi in Nylon con design aperto o chiuso (optional).

Poltrone girevoli proposte con oscillante a fulcro avanzato TX36, o con oscillante a fulcro centrale A12. Base a 5 razze in Nylon Ø 68 cm in colore nero (NY), o bianco (BI) per la versione White, oppure Ø 68 cm in alluminio finitura lucida (LU). Ruote Ø 65 mm frenate/gommate per pavimenti duri in abbinamento alla struttura. Versione ospiti girevole con base Spider in Nylon Ø 67 cm in colore nero (NY) o bianco (BI) per la versione White.

Executive series made entirely of self-supporting mesh (Polyester/Polyester elastomer), available in a Black version (black structure/black mesh) or a White version (RAL 9003 white structure/light grey or black mesh).

The easy chairs come in two heights, high backrest with integrated headrest and 5-star swivel base, or medium backrest, available with 5-star swivel base and spider base (4-star with glides, seat not height-adjustable). Fixed Nylon armrests with open or closed design (optional).

Swivel easy chairs with knee-tilt mechanism (TX36) or central tilt mechanism (A12). 5-star Nylon base (Ø 68 cm) in black (NY), or white (BI), for the White variant, or Ø 68 cm in polished aluminium finish (LU). Braked-rubber castors (Ø 65 mm) for hard floors matching the structure.

Série direction entièrement en résille autoportante (Polyester/Polyélastomère), proposée en version Black (structure noire/résille noire) ou en version White (structure blanche RAL 9003/résille gris clair ou noire).

Les fauteuils sont disponibles en deux hauteurs, dossier haut avec appuie-tête intégré avec piètement pivotant à 5 branches ou avec dossier moyen, disponible avec piètement pivotant à 5 branches et avec piètement «spider» (à 4 branches avec patins, assise non réglable en hauteur). Accoudoirs fixes en Nylon avec design ouvert ou fermé (option).

Fauteuils pivotants proposées avec mécanisme basculant à axe déporté TX36, ou avec mécanisme basculant à axe central A12. Piètement à 5 branches en Nylon Ø 68 cm en noir (NY), blanc (BI) pour la version White, ou Ø 68 cm en aluminium finition polie (LU). Roulettes Ø 65 mm freinées/souples pour sols durs assorties à la structure. Version visiteur pivotante avec piètement «spider» en Nylon Ø 67 cm en noir (NY) ou blanc (BI) pour la version White.

Chefsesselreihe, komplett aus selbsttragendem Netz (Polyester/Polyelastomer), erhältlich in Ausführung Black (schwarzes Gestell/schwarzes Netz) oder White (weißes Gestell RAL 9003/hellgrau oder schwarzes Netz).

Die Sessel sind in zwei Höhen erhältlich: hohe Rückenlehne mit integrierter Kopfstütze und 5-Stern-Drehfuß oder mittlere Rückenlehne, erhältlich mit 5-Stern-Drehfuß und Fußkreuz (4 Sterne mit Füßen, Sitz nicht höhenverstellbar). Feste Armlehnen aus Nylon mit offenem Design oder als Ringarmlehnen (optional).

Drehsessel mit Wippmechanik mit vorgeseztem Drehpunkt TX36 oder Wippmechanik mit zentralem Drehpunkt A12. 5-Stern-Fußkreuz Ø 68 cm aus Nylon in schwarz (NY) oder weiß (BI) für die Ausführung White oder Ø 68 cm aus poliertem Aluminium (LU). Gebremste-Rollen mit weichem Lauffring Ø 65 mm für Hartböden, passend zum Gestell. Ausführung Besucherstuhl mit Sternfuß aus Nylon Ø 67 cm in schwarz (NY) oder weiß (BI) für die Ausführung White.

Base | Base | Piètement | Fußkreuz



NY - Ø 68

BI - Ø 68

LU - Ø 68

LU - Ø 68



NYN - Ø 67

NYBI - Ø 67

Braccioli | Armrests | Accoudoirs | Armlehnen



BRA-N

BRA-W

Op. BRC-N

Op. BRC-W

Rete | Mesh | Résille | Netzbespannung

(Solo per My Mesh | Only for My Mesh | Uniquement pour My Mesh | Nur für My Mesh
 47% Polyester - 53% Polyelastomerisch)

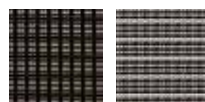

MY1

MY2

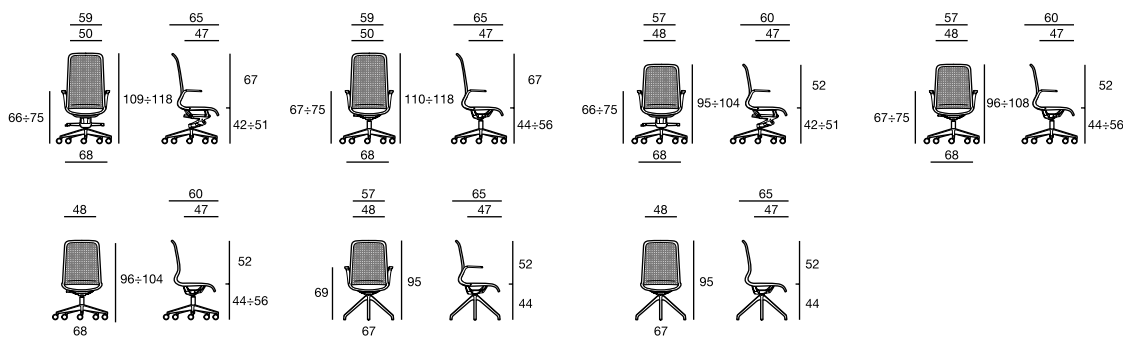



EXECUTIVE

MASTER



Conforme alla norma UNI EN 1335, tipologia C
 Conforms the UNI EN 1335 standards, C class
 Conforme aux normes UNI EN 1335 classe C
 Entsprechend der Richtlinien EN 1335 Klasse C



1/IM = Disponibile per alcuni rivestimenti a cartella
 Available for some covering only
 À disposition que pour quelque revêtement
 Erhältlich für einige Bezüge nach Stoff-Mustermappe

Serie direzionale composta da poltrona e da sedia ospiti con base a slitta. La poltrona è proposta con schienale alto dotato di poggiatesta fisso (H 73 cm) o con schienale alto senza poggiatesta (H 55 cm). Schienale regolabile in altezza con sistema Up&Down completamente rivestito tranne la parte bassa posteriore essendo presente il carter schienale in Polipropilene di colore nero a copertura della lama per la regolazione in altezza; il carter può essere comunque tappezzato dello stesso rivestimento della poltrona (optional).

Serie dotata di meccanismo Synchro SY9 con traslazione del sedile.

Disponibile con braccioli fissi in alluminio finitura lucida con poggibraccia in Poliuretano colore nero oppure tappezzati (optional), oppure regolabili a tre vie. Base Ø 70 cm in Nylon colore nero (NY) oppure in alluminio finitura lucida (LU). Ruote Ø 50 mm frenate/gommate per pavimenti duri. Poltrona monocoocca per ospiti in versione fissa con schienale H 48 cm dal sedile. Base a slitta Ø 25 mm, con braccioli integrati e poggibraccia in Polipropilene colore nero, disponibile con finitura nera (N) o cromata (CR).

Executive chair consisting of easy chair and visitor chair with sled base. The armchair comes with high backrest and fixed headrest (H 73 cm) or with high backrest and no headrest (H 55 cm). Height-adjustable backrest with Up&Down system, fully upholstered except for the lower rear which has a black Polypropylene casing covering the height adjustment plate; the casing can also be upholstered with the same covering as the chair (optional). Series comes with Synchro SY9 mechanism with seat slider.

Available with fixed armrests in polished aluminium finish with black Polyurethane or upholstered (optional) arm pad, or with three-way adjustable armrests. Ø 70 cm base in black Nylon (NY) or in polished aluminium (LU). Braked-rubber castors (Ø 50 mm) for hard floors.

Fixed, single-shell visitor chair with backrest (H 48 cm from seat). Sled base (Ø 25 mm) with integrated armrests and black Polypropylene arm pads, available with black (N) or chrome (CR) finish.

Série direction composée d'un fauteuil et d'une chaise visiteur avec piètement luge. Le fauteuil est proposé avec dossier haut muni d'appui-tête fixe (H 73 cm) ou avec dossier haut sans appui-tête (H 55 cm). Dossier réglable en hauteur avec système Up&Down entièrement revêtu à l'exception de la partie inférieure arrière, du fait de la présence du carter de dossier en Polypropylène noir pour recouvrir la lame de réglage en hauteur; le carter peut toutefois être tapissé avec le même revêtement que le fauteuil (option).

Série équipée du mécanisme Synchro SY9 avec translation de l'assise.

Disponibile con accoudoirs fixes en aluminium finition polie avec manchettes en Polyuréthane de couleur noire ou tapissées (option), ou réglables dans trois directions. Base Ø 70 cm en Nylon de couleur noire (NY) ou en aluminium finition polie (LU). Roulettes Ø 50 mm freinées/souples pour sols durs. Fauteuil monocoque pour visiteurs en version fixe, avec dossier à 48 cm de hauteur de l'assise. Piètement luge Ø 25 mm, avec accoudoirs intégrés et manchettes en Polypropylène noir, disponible dans la finition noire (N) ou chromée (CR).

Chefsesselreihe bestehend aus Sessel und Besucherstuhl mit Kufengestell. Der Sessel wird mit hoher Rückenlehne und fester Kopfstütze (H. 73 cm) oder hoher Rückenlehne ohne Kopfstütze (H. 55 cm) angeboten. Über Up-&-Down-System höhenverstellbare Rückenlehne, vollständig bezogen mit Ausnahme des unteren hinteren Teils, da die Rückenlehne mit einer Schale aus schwarzem Polypropylen versehen ist, die den Träger für die Höhenverstellung abdeckt. Die Abdeckung kann jedoch mit dem gleichen Bezug wie der Sessel bezogen werden (optional).

Die Reihe ist mit Synchronmechanik SY9 mit Sitzflächenverschiebung ausgestattet.

Erhältlich mit festen Armlehnen aus poliertem Aluminium mit Armauflagen aus schwarzem Polyurethan oder bezogen (optional) oder mit dreifach verstellbaren Armlehnen. Fußkreuz Ø 70 cm aus Nylon in schwarz (NY) oder aus poliertem Aluminium (LU). Gebremste Rollen mit weichem Lauffring Ø 50 mm für Hartböden.

Besuchersessel mit Sitzschale in fester Ausführung, mit 48 cm hoher Rückenlehne ab Sitz. Freischwingermodell Ø 25 mm, mit integrierten Armlehnen und Armauflage aus schwarzem Polypropylen, erhältlich in den Ausführungen schwarz (N) oder verchromt (CR).

Base | Base | Piètement | Fußkreuz



NY - Ø 70



LU - Ø 70



N



CR

Braccioli | Armrests | Accoudoirs | Armlehnen



5B/LU



8BRA



10BH - 3D

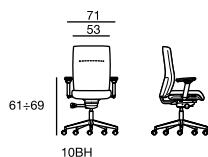
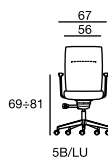
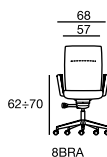
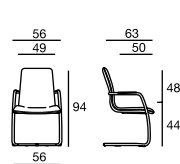
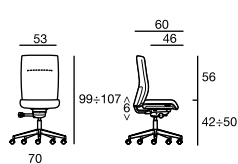
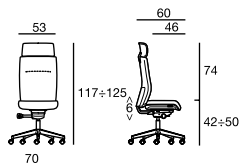

EXECUTIVE

JOLLY

Conforme alla norma UNI EN 1335, tipologia C
 Conforms the UNI EN 1335 standards, C class
 Conforme aux normes UNI EN 1335 classe C
 Entsprechend der Richtlinien EN 1335 Klasse C



1/IM = Disponibile per alcuni rivestimenti a cartella
 Available for some covering only
 À disposition que pour quelque revêtement
 Erhältlich für einige Bezüge nach Stoff-Mustermappe

Serie direzionale proposta in tre varianti: «RETE» (monotelo di rete bianco o nero), «TAP-RETE» (monotelo di rete bianco o nero, con sedile rivestito da fodera tappezzata amovibile con Velcro), «TAP» monotelo di rete bianco o nero, completamente rivestito con ogni rivestimento a cartella (retro accoppiato al telo di rete, fronte tappezzato amovibile con Velcro).

Due dimensioni di schienale: alto per la direzionale e medio per la ospiti, caratterizzate entrambe dalla struttura della seduta e dei braccioli in tubolare di acciaio in finitura cromata (CR). Poltrone girevoli proposte con oscillante a fulcro centrale A19 o con solo alzo a gas A13.

Base Ø 70 cm in alluminio finitura lucida (LU). Ruote Ø 50 mm frenate/gommate per pavimenti duri.

Sedia ospiti con base a slitta con o senza braccioli, proposta con finitura cromata (CR).

Executive chair in three versions: «RETE» (single-layer black or white mesh), «TAP-RETE» (single-layer black or white mesh, upholstered seat with removable cover fixed in place with Velcro), «TAP» (single-layer black or white mesh, fully upholstered with all listed coverings (mesh-backed rear, removable front cover fixed in place with Velcro). Two backrest sizes: high for executive chairs and medium for visitor chairs, both featuring tubular steel framework for seat and armrests in chrome (CR) finish. Swivel armchair with central tilt mechanism (A19) or with gas lift (A13) only.

Ø 70 cm base in polished aluminium (LU). Braked-rubber castors (Ø 50 mm) for hard floors. Visitor chair with sled base, with or without armrests, available with chrome (CR) finish.

Série direction proposée en trois variantes: «RETE» (toile unique en résille noire ou blanche), «TAP-RETE» (toile unique en résille noire ou blanche, avec assise revêtue d'une housse tapissée amovible fixée par scratchs), «TAP» (toile unique en résille noire ou blanche), entièrement revêtue avec les revêtements disponibles dans le nuancier (face arrière couplée à la résille, face avant tapissée amovible fixée par scratchs).

Deux dimensions de dossier: haut pour le modèle direction et moyen pour le modèle visiteur, les deux étant caractérisés par la structure de l'assise et les accoudoirs en tube d'acier finition chromée (CR). Fauteuils pivotants proposés avec mécanisme basculant à axe central A19 ou avec uniquement vérin à gaz A13. Piètement Ø 70 cm en aluminium finition polie (LU). Roulettes Ø 50 mm freinées/souples pour sols durs.

Chaise visiteur avec piètement luge, avec ou sans accoudoirs, proposée dans la finition chromée (CR).

Chefsesselreihe in drei Ausführungen: «RETE» (einlagige weiße oder schwarze Netzbespannung), «TAP-RETE» (einlagige weiße oder schwarze Netzbespannung, abnehmbarer Sitzbezug mit Klettverschluss), «TAP», einlagige weiße oder schwarze Netzbespannung, vollständig überzogen, mit allen Bezügen nach Stoff-Mustermappe (Rückseite mit dem Netzstoff kaschiert, bezogene Vorderseite abnehmbar mit Klettverschluss).

Zwei Rückenlehnenhöhen: hohe Rückenlehne für den Besucherstuhl und mittlere Rückenlehne für den Besucherstuhl, beide durch das Sitzgestell und die Armlehnen aus Stahlrohr in verchromter Ausführung (CR) gekennzeichnet. Dreh-Chefsessel mit Wippmechanik mit zentralem Drehpunkt A19 oder Höhenverstellung mit Gaslift A13. Fußkreuz Ø 70 cm aus poliertem Aluminium (LU). Gebremste Rollen mit weichem Laufring Ø 50 mm für Hartböden.

Besucherstuhl als Freischwingermodell mit oder ohne Armlehnen, angeboten in der Ausführung verchromt (CR).

Base | Base | Piètement | Fußkreuz

LU - Ø 70



CR

Rete | Mesh | Résille | Netzbespannung

RETE J: 70% PVC - 30% PES



J02

J01

Braccioli | Armrests | Accoudoirs | Armlehnen

JYBRA - FIX

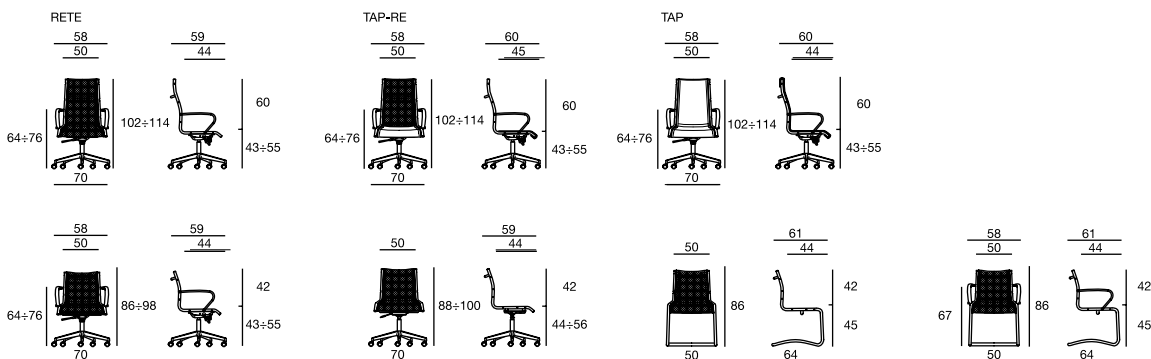



EXECUTIVE

SILVER 2100



Conforme alla norma UNI EN 1335, tipologia C
 Conforms the UNI EN 1335 standards, C class
 Conforme aux normes UNI EN 1335 classe C
 Entsprechend der Richtlinien EN 1335 Klasse C



1/IM = Disponibile per alcuni rivestimenti a cartella
 Available for some covering only
 À disposition que pour quelque revêtement
 Erhältlich für einige Bezüge nach Stoff-Mustermappe

Serie direzionale caratterizzata dalla monoscocca in legno multistrati proposta in tre altezze di schienale: schienale alto con poggiatesta integrata, schienale alto e schienale medio.

Serie dotata di meccanismo oscillante a fulcro avanzato AX7 oppure, con oscillante centrale A19 o con solo alzo a gas A13.

Poltrona girevole disponibile con braccioli in piatto d'acciaio con poggia braccia imbottito e tappezzato nel rivestimento della sedia.

Versioni girevoli con base a 5 razze Ø 70 cm in Nylon colore nero (NY) oppure in alluminio finitura lucida (LU). Ruote Ø 50 mm frenate/gommate per pavimenti duri. Poltrona monoscocca per ospiti in versione fissa con schienale H 48 cm dal sedile. Base a slitta Ø 25 mm, con braccioli integrati e poggia braccia in Polipropilene colore nero, disponibile con finitura nera (N) o cromata (CR).

Executive series featuring plywood single-shell with three backrest heights: high backrest with integrated headrest, high backrest and medium backrest.

Series fitted with knee-tilt mechanism (AX7), central tilt mechanism (A19) or gas lift (A13) only. Swivel armchair with armrests in flat steel and cushioned arm pads upholstered in the same cover as the seat.

Swivel versions with 5-star base (Ø 70 cm) in black Nylon (NY) or in polished aluminium (LU). Braked-rubber castors (Ø 50 mm) for hard floors. Fixed, single-shell visitor chair with backrest (H 48 cm from seat). Sled base (Ø 25 mm) with integrated armrests and black Polypropylene arm pads, available with black (N) or chrome (CR) finish.

Série direction caractérisée par la monocoque en bois multiplis proposée en trois hauteurs de dossier: dossier haut avec appuie-tête intégré, dossier haut et dossier moyen.

Série munie de mécanisme basculant à axe avancé AX7 ou avec mécanisme basculant à axe central A19 ou avec uniquement vérin à gaz A13. Fauteuil pivotant disponible avec accoudoirs en acier plat avec manchettes rembourrées et tapissées dans le revêtement de la chaise.

Versions pivotantes avec piètement à 5 branches Ø 70 cm en Nylon de couleur noire (NY) ou en aluminium finition polie (LU). Roulettes Ø 50 mm freinées/souples pour sols durs. Fauteuil monocoque pour visiteurs en version fixe, avec dossier à 48 cm de hauteur de l'assise. Piètement luge Ø 25 mm, avec accoudoirs intégrés et manchettes en Polypropylène noir, disponible dans la finition noire (N) ou chromée (CR).

Chefsesselreihe mit Sitzschale aus Schichtholz in drei Rückenlehnenhöhen: hohe Rückenlehne mit integrierter Kopfstütze, hohe Rückenlehne und mittlere Rückenlehne.

Erhältlich mit Wippmechanik mit vorgesetztem Drehpunkt AX7 oder mit zentralem Drehpunkt A19 oder nur mit Höhenverstellung mit Gaslift A13.

Drehstuhl mit Armlehnen aus Flachstahl und gepolsterten Armauflagen mit dem gleichen Bezug wie der Stuhl.

Drehmodelle mit 5-Stern-Fußkreuz Ø 70 cm aus Nylon in schwarz (NY) oder aus poliertem Aluminium (LU). Gebremste Rollen mit weichem Laufring Ø 50 mm für Hartböden. Besuchersessel mit Sitzschale in fester Ausführung, mit 48 cm hoher Rückenlehne ab Sitz. Freischwingermodell Ø 25 mm, mit integrierten Armlehnen und Armauflage aus schwarzem Polypropylen, erhältlich in den Ausführungen schwarz (N) oder verchromt (CR).

Base | Base | Piètement | Fußkreuz



NY - Ø 70



LU - Ø 70



N



CR

Braccioli | Armrests | Accoudoirs | Armlehnen



21/AC - FIX

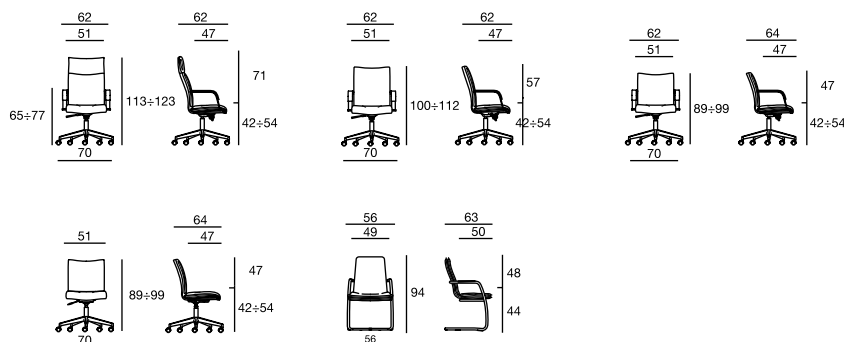

TASK

X1

All Mesh/Mid Mesh/All Air



conforme al D.Lgs. 81/08 con prove EN 1335-1:2020/EN 1335-2:2018, tipologia B
 conforms the EN 1335-1:2020/EN 1335-2:2018 standards, B class
 conforme aux normes EN 1335-1:2020/EN 1335-2:2018, classe B
 Entsprechend der Richtlinien EN 1335-1:2020/EN 1335-2:2018, Klasse B



1/IM = MID MESH Disponibile per alcuni rivestimenti a cartella
 Available for some covering only
 À disposition que pour quelque revêtement
 Erhältlich für einige Bezüge nach Stoff-Mustermappe

Serie operativa proposta con struttura nera N (All Mesh, Mid Mesh, All Air) e bianca BI (All Air). Tutte le versioni sono proposte in versione "operativa" con Synchro SLVR2 (Synchro evoluto con traslazione del sedile), Synchro PSY6 (Synchro autoregolante con traslazione del sedile) e in versione "Meeting" con Synchro PSY8 (Synchro autoregolante). Le versioni operative sono proposte con o senza poggiatesta 2D. Lo schienale fisso, quando senza poggiatesta è alto 60 cm (dal sedile). Versione "operativa" con regolazione lombare 2D, mentre la versione "Meeting" è senza regolazione lombare. Per ogni versione sono disponibili 4 tipi di braccioli: 20BRA fisso (suggerito per la versione Meeting), 22BH regolabile 2D, 23BH regolabile 3D, 34BH regolabile 4D.

Task series proposed with black N (All Mesh, Mid Mesh, All Air) and white BI (All Air) structure. All versions are offered in the "task" version with Synchro SLVR2 (evolved Synchro with seat translation), Synchro PSY6 (self-adjusting Synchro with seat translation) and in the "Meeting" version with Synchro PSY8 (self-adjusting Synchro). The task versions are offered with or without 2D headrest. The fixed backrest, when without headrest, is 60 cm high (from the seat). "Task" version with 2D lumbar adjustment, while the "Meeting" version is without lumbar adjustment. For each version, 4 types of armrests are available: 20BRA fixed (suggested for the Meeting version), 22BH adjustable 2D, 23BH adjustable 3D, 34BH adjustable 4D.

Série opérationnelle proposée avec structure N noire (All Mesh, Mid Mesh, All Air) et blanche BI (All Air). Toutes les versions sont proposées en version "opérationnelle" avec Synchro SLVR2 (Synchro évolué avec translation du siège), Synchro PSY6 (Synchro auto-ajustable avec translation du siège) et en version "Meeting" avec Synchro PSY8 (Synchro auto-ajustable). Les versions opérationnelles sont proposées avec ou sans appui-tête 2D. Le dossier fixe, lorsqu'il est sans appui-tête, a une hauteur de 60 cm (à partir de l'assise). Version "Opérationnelle" avec réglage lombaire 2D, tandis que la version "Meeting" est sans réglage lombaire. Pour chaque version, 4 types d'accoudoirs sont disponibles: 20BRA fixes (suggéré pour la version Meeting), 22BH réglables 2D, 23BH réglables 3D, 34BH réglables 4D.

Arbeitsstuhlreihe mit Gestell in schwarz N (All Mesh, Mid Mesh, All Air) und weiß BI (All Air). Alle Ausführungen sind als Arbeitsstuhl mit Synchro SLVR2 (Folge-Synchronmechanik mit Sitzflächenverschiebung), Synchro PSY6 (Synchronmechanik mit automatischer Einstellung und Sitzflächenverschiebung) sowie in der Version "Meeting" mit Synchro PSY8 (Synchronmechanik mit automatischer Einstellung) erhältlich. Die Arbeitsstuhlausführungen sind mit oder ohne 2D-Kopfstütze lieferbar. Die feste Rückenlehne ohne Kopfstütze ist 60 cm hoch (ab Sitz). Arbeitsstuhlausführung mit Höhenverstellung der 2D-Lendenwirbelstütze, während die Version "Meeting" keine höhenverstellbare Lendenwirbelstütze hat. Für alle Ausführungen stehen 4 Arten von Armlehnen zur Auswahl: 20BRA fest (für die Meeting-Version empfohlen), 22BH 2fach verstellbar, 23BH 3fach verstellbar, 34BH 4fach verstellbar.

Base | Base | Piètement | Fußkreuz

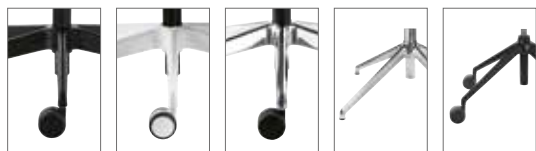

NY - Ø 70 BI - Ø 70 LU - Ø 68 N - LU - BI

OP. Ruote | Castors | Roulettes | Räder



op. A22G-18H op. A22G-18HW

Versioni | Versions | Versions | Versionen



ALL MESH MID MESH ALL AIR Black ALL AIR White

Braccioli | Armrests | Accoudoirs | Armlehnen

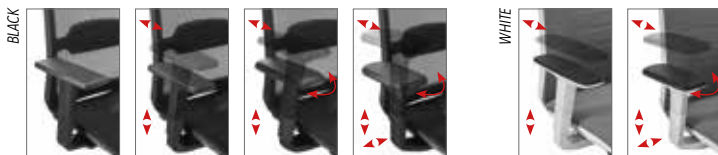

20BRA 22BH - 2D 23BH - 3D 34BH - 4D 22BHW - 2D 34BHW - 4D

Reti | Mesh | Réseille | Netzbespannung

RETE MX 60% PA - 40% PES RETE N: 100% PES 330 gr/m2

All Mesh | Mid Mesh | All Air

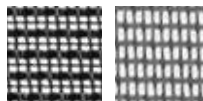

MX33 MX07

Mid Mesh

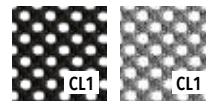

N01 N16

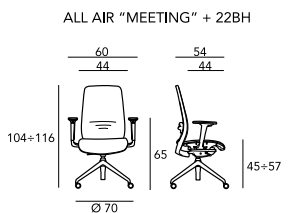
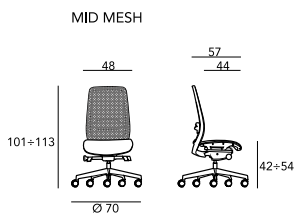
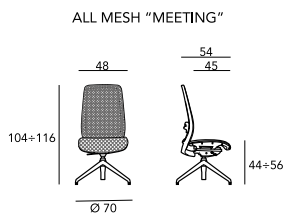
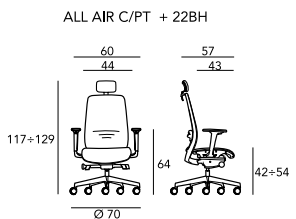
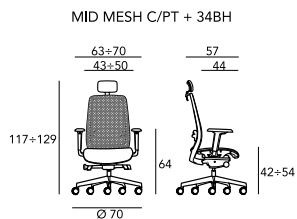
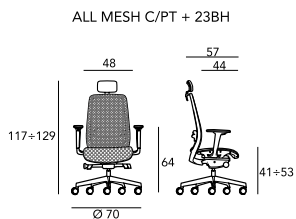



TASK

TWIST

rete



Conforme al D.Lgs. 81/08 con prove EN 1335-1:2020/EN 1335-2:2018, tipologia B
 Conforms the EN 1335-1:2020/EN 1335-2:2018 standards, B class
 Conforme aux normes EN 1335-1:2020/EN 1335-2:2018, classe B
 Entsprechend der Richtlinien EN 1335-1:2020/EN 1335-2:2018, Klasse B



1/IM = RETE Rivestimenti King-Leder e rete nera N01
 King-Leder coverings and black colour mesh N01
 Revêtements King-Leder et résille noire N01
 Bezug King-Leder und schwarzes Netz N01

Serie operativa proposta con struttura in finitura nera (Black) e bianca (White - RAL 9016). Lo schienale fisso rivestito in rete, è proposto in una sola altezza (H 55 cm) ed è dotato di fascia lombare regolabile in altezza (+/- 5 cm). La rete è di tipo N, disponibile in 7 colori, il sedile è tappezzato e disponibile in tutti i rivestimenti a cartella. In dotazione 4 meccanismi: Synchro evoluto SLYR2, Synchro autoregolante PSY6 con traslazione del sedile, Synchro SY5 senza traslazione del sedile, Contatto permanente PCS4 con regolazione della tensione. Colonna a gas in CL4 di colore nero, base in Nylon Ø 70 cm nera o bianca, oppure in alluminio Ø 68 cm con finitura lucida, ruote frenate/gommate da 65 mm nere o bianche. I braccioli proposti per la versione Black sono 4: 20BRA fisso, 5BH 1D, 22BH 2D, 23BH 3D, mentre per la versione White sono 2: 5BHW 1D e 22BHW 2D.

Task series proposed with frame in black (Black) and white (White - RAL 9016) finish. The fixed mesh backrest is available only in a height (H 55 cm) and is equipped with a lumbar support adjustable in height (+/- 5 cm). The mesh is of type N, available in 7 colors, the seat is upholstered and available in all the coverings in the card. Supplied with 4 mechanisms: SLYR2 evolved Synchro, PSY6 self-adjusting Synchro with sliding seat, SY5 Synchro without sliding seat, Permanent contact PCS4 with tension adjustment. Gas column CL4 in black, base in Nylon Ø 70 cm black or white, or in aluminium Ø 68 cm with polished finish, braked / rubber castors 65 mm in black or white. The armrests proposed for the Black version are 4: 20BRA fixed, 5BH 1D, 22BH 2D, 23BH 3D, while for the White version they are 2: 5BHW 1D and 22BHW 2D.

Série opératoire proposée avec structure en finition noire (Black) et blanche (White - RAL 9016). Le dossier en résille est fixe et il disponible uniquement dans une hauteur (H 55 cm) et est équipé d'une appui lombaire réglable en hauteur (+/- 5 cm). La résille est de type N, disponible en 7 couleurs, l'assise est rembourrée et disponible dans tous les revêtements du nuancier. Livré avec 4 mécanismes: le Synchro évolué SLYR2, Synchro autorégulant PSY6 avec translation assise, Synchro SY5 sans translation assise, le contact permanent PCS4 avec réglage de tension. Colonne à gaz en CL4 noir, base en Nylon Ø 70 cm noir ou blanc, ou en aluminium Ø 68 cm avec finition polie, roulettes freinées de 65 mm en noir ou blanc pour sols durs. Les accoudoirs proposés pour la version Black sont au nombre de 4: 20BRA fixes, 5BH 1D, 22BH 2D, 23BH 3D, tandis que pour la version White ils sont au nombre de 2: 5BHW 1D et 22BHW 2D.

Arbeitsstuhlreihe mit Gestell in schwarz (Black) oder weiß (White - RAL 9016). Die (H 55 cm) hohe feste Rückenlehne mit Netzbespannung verfügt über eine höhenverstellbare Lendenwirbelstütze (+/- 5 cm). Die Netzbespannung Typ N ist in 7 Farben und der Sitz mit allen Bezügen nach Stoff-Mustermappe erhältlich. 4 Mechaniken gehören zur Ausstattung: Synchro-Folgemodell SLYR2, Synchronmechanik PSY6 mit automatischer Einstellung und Sitzflächenverschiebung, Synchronmechanik SY5 ohne Sitzflächenverschiebung, Permanentkontakt PCS4 mit Spannungsregulierung. Gaslift KL4 in schwarz, Fußkreuz aus Nylon Ø 70 cm in schwarz, weiß oder aus poliertem Aluminium Ø 68 cm, mit Hartbodenrollen Ø 65 mm in schwarz oder weiß. 4 Armlehnen stehen für die Ausführung Black zur Auswahl: 20BRA fest, 5BH 1D, 22BH 2D, 23BH 3D, für die Ausführung White sind es 2: 5BHW 1D und 22BHW 2D.

Base | Base | Piètement | Fußkreuz



NY - Ø 70

BI - Ø 70

LU - Ø 68

LU - Ø 68

Rete | Mesh | Résille | Netzbespannung

RETE N: 100% PES 330 gr/m2



N06

N16

N01

N11

N13

N14

N12

Braccioli | Armrests | Accoudoirs | Armlehnen

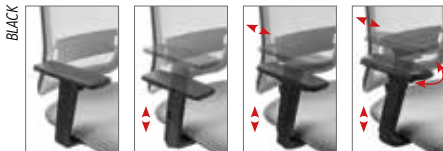

20BRA

5BH

22BH - 2D

23BH - 3D

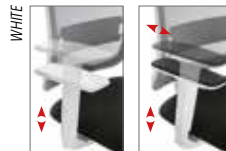

5BHW

22BHW - 2D

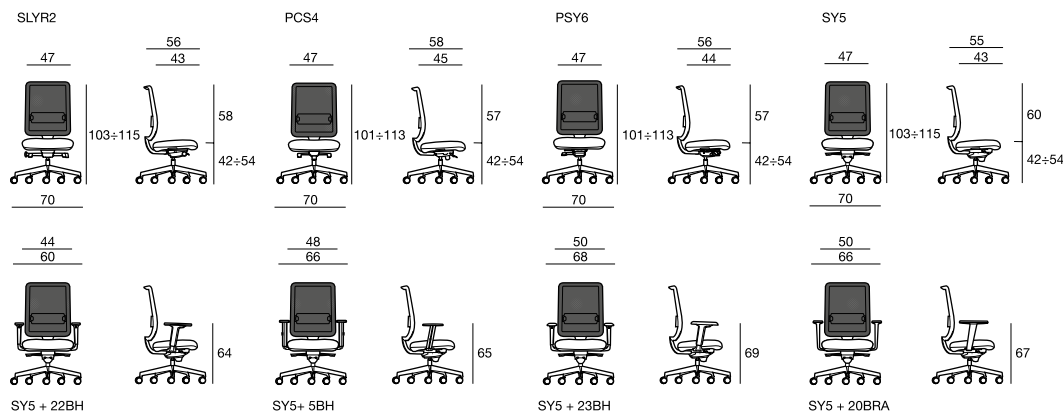

TASK

TWIST TT



Conforme al D.Lgs. 81/08 con prove EN 1335-1:2020/EN 1335-2:2018, tipologia B
 Conforms the EN 1335-1:2020/EN 1335-2:2018 standards, B class
 Conforme aux normes EN 1335-1:2020/EN 1335-2:2018, classe B
 Entsprechend der Richtlinien EN 1335-1:2020/EN 1335-2:2018, Klasse B



1/IM = Disponibile per alcuni rivestimenti a cartella
 Available for some covering only
 À disposition que pour quelque revêtement
 Erhältlich für einige Bezüge nach Stoff-Mustermappe

Serie proposta con struttura in finitura nera (Black) e bianca (White - RAL 9016). Lo schienale, regolabile in altezza con sistema Up&Down per tutti i meccanismi, è proposto solo in altezza H 56 cm ed è dotato di carter protettivo posteriore in plastica. Il sedile e lo schienale sono tappezzati e disponibili in tutti i rivestimenti a cartella.

Sono proposti 5 meccanismi di serie: Synchro evoluto SLYR2, Synchro autoregolante PSY6 con traslazione del sedile, Synchro SY5 senza traslazione del sedile, Contatto permanente PCS4 con regolazione della tensione, Contatto permanente PC. Colonna a gas in CL4, base in Nylon Ø 70 cm nera o bianca, oppure in alluminio Ø 68 cm con finitura lucida, ruote frenate/gommate da 65 mm nere o bianche. I braccioli proposti per la versione Black sono 4: 20BRA fisso, 5BH 1D, 22BH 2D, 23BH 3D, mentre per la versione White sono 2: 5BHW 1D e 22BHW 2D.

Series proposed with frame in black (Black) and white (White - RAL 9016) finish. The backrest, adjustable in height with the Up&Down system for all mechanisms, is proposed only in a height 56 cm and is equipped with a rear protective plastic cover. The seat and backrest are upholstered and available in all coverings in the card.

Supplied with 5 mechanisms: SLYR2 evolved Synchro, PSY6 self-adjusting Synchro with sliding seat, SY5 Synchro without sliding seat, Permanent contact PCS4 with tension adjustment, PC permanent contact. Gas column in CL4, base in Nylon Ø 70 cm black or white, or in aluminium Ø 68 cm with polished finish, braked/rubber castors of 65 mm black or white. The armrests proposed for the Black version are 4: 20BRA fixed, 5BH 1D, 22BH 2D, 23BH 3D, while for the White version they are 2: 5BHW 1D and 22BHW 2D.

Série proposée avec structure en finition noire (Black) et blanche (White - RAL 9016). Le dossier, réglable en hauteur avec le système Up&Down pour tous les mécanismes, est proposé uniquement en hauteur 56 cm et est équipé d'un carter de protection arrière en plastique. L'assise et le dossier sont rembourrés et disponibles dans tous les revêtements dans les nuanciers.

Livré avec 5 mécanismes: le Synchro évolué SLYR2, Synchro autorégulant PSY6 avec translation assise, Synchro SY5 sans translation assise, le contact permanent PCS4 avec réglage de tension, le contact permanent PC.

Colonne à gaz en CL4, base en Nylon Ø 70 cm noir ou blanc, ou en aluminium Ø 68 cm avec finition polie, roulettes freinées de 65 mm en noir ou blanc pour sols durs. Les accoudoirs proposés pour la version Black sont au nombre de 4: 20BRA fixe, 5BH 1D, 22BH 2D, 23BH 3D, tandis que pour la version White ce sont 2: 5BHW 1D et 22BHW 2D.

Stuhlreihe mit Gestell in schwarz (Black) oder weiß (White - RAL 9016). Die über Up-&Down-System höhenverstellbare Rückenlehne ist in Kombination mit allen Mechaniken 56 cm hoch und mit einer Kunststoffschutzschale ausgestattet. Sitz und Rückenlehne sind gepolstert und mit allen Bezügen nach Stoff-Mustermappe erhältlich.

5 Mechaniken stehen serienmäßig zur Auswahl: Synchro-Folgemodell SLYR2, Synchronmechanik PSY6 mit automatischer Einstellung und Sitzflächenverschiebung, Synchronmechanik SY5 ohne Sitzflächenverschiebung, Permanentkontakt PCS4 mit Spannungsregulierung, Permanentkontakt PC. Gaslift KL4, Fußkreuz aus Nylon Ø 70 cm in schwarz, weiß oder aus poliertem Aluminium Ø 68 cm, mit Hartbodenrollen Ø 65 mm in schwarz oder weiß. 4 Armlehnen stehen für die Ausführung Black zur Auswahl: 20BRA fest, 5BH 1D, 22BH 2D, 23BH 3D, für die Ausführung White sind es 2: 5BHW 1D und 22BHW 2D.

Base | Base | Piètement | Fußkreuz



NY - Ø 70

BI - Ø 70

LU - Ø 68

LU - Ø 68

Braccioli | Armrests | Accoudoirs | Armlehnen

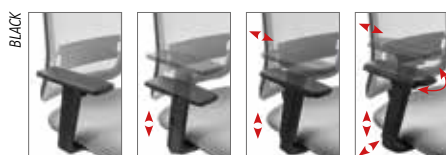

20BRA

5BH

22BH - 2D

23BH - 3D

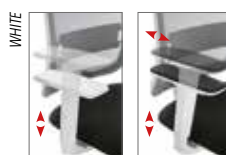

5BHW

22BHW - 2D

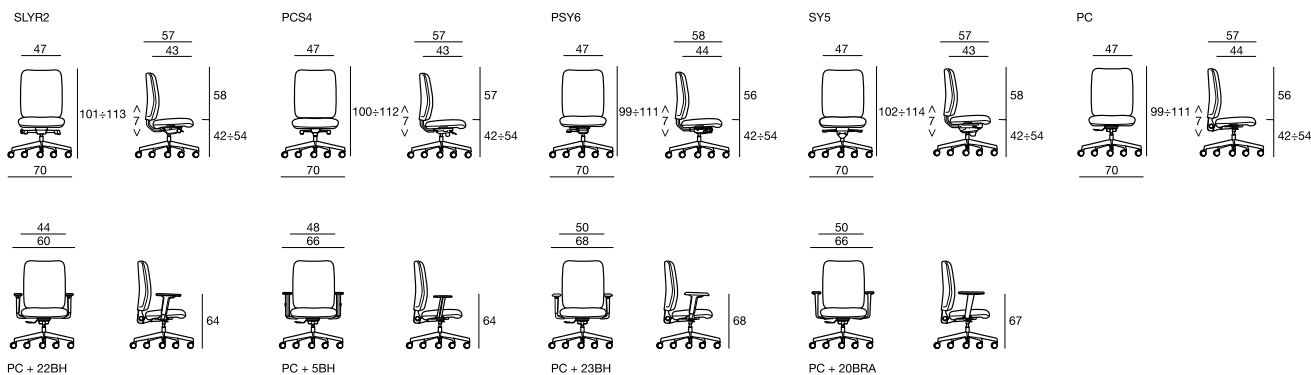



TASK

COBRA

rete/air



Conforme al D.Lgs. 81/08 con prove EN 1335-1:2020/EN 1335-2:2018, tipologia B
 Conforms the EN 1335-1:2020/EN 1335-2:2018 standards, B class
 Conforme aux normes EN 1335-1:2020/EN 1335-2:2018, classe B
 Entsprechend der Richtlinien EN 1335-1:2020/EN 1335-2:2018, Klasse B



1/IM = AIR Disponibile per alcuni rivestimenti a cartella
 Available for some covering only
 À disposition que pour quelque revêtement
 Erhältlich für einige Bezüge nach Stoff-Mustermappe

RETE Rivestimenti King-Leder e rete nera N01
 King-Leder coverings and black colour mesh N01
 Revêtements King-Leder et réssille noire N01
 Bezug King-Leder und schwarzes Netz N01

Serie operativa proposta con struttura nera (N) o bianca detta White (BI-RAL 9010) con schienale fisso (H 57 cm) disponibile in versione RETE (schienale in rete) o versione AIR (schienale dotato di membrana composta da strato di gomma da 5 mm abbinata a rete N, rivestita sulle due facce). Disponibile anche in versione con poggiatesta regolabile 2D (regolabile in altezza e inclinazione, imbottito e tappezzato con carter di protezione in Polipropilene). Supporto lombare regolabile 6 cm in altezza CB-ADH nero o CB-ADHW bianco oppure regolabile 2D (altezza 6 cm e profondità 15 mm) CB-ADH-2D nero o CBADH-2DW bianco. Sono proposti 3 meccanismi di serie: Synchro evoluto SLYR2, Synchro SLY4 con traslazione del sedile e Contatto Permanente PCS4 con regolazione della tensione. Colonna a gas in CL4, base in Nylon Ø 70 cm nera o bianca, oppure in alluminio Ø 68 cm con finitura lucida, ruote frenate/gommate da 65 mm nere o bianche. I braccioli proposti per la versione Black sono 5: 20BRA fisso, 5BH 1D, 22BH 2D, 23BH 3D e 14BH 4D mentre per la versione White sono 2: 5BHW 1D, 22BHW 2D e 13BHW 3D.

Task chair available with black (N) or white (BI-RAL 9010 - referred to as White) frame and fixed backrest (H 57 cm), in RETE (mesh backrest) and AIR (backrest complete with membrane formed of 5-mm thick foam layer combined with N-type mesh, upholstered on both sides). Also available with 2D adjustable headrest (height-adjustable and inclination, padded and upholstered with Polypropylene protective cover). Lumbar support is height-adjustable to 6 cm, CB-ADH black or CB-ADHW white, or 2D-adjustable (height 6 cm and depth 15 mm), CB-ADH-2D black or CBADH-2DW white. 3 standard mechanisms possible: Evolved Synchro SLYR2, Synchro SLY4 with seat slider, and PCS4 Permanent Contact with tension adjustment. Gas lift in CL4, black or white Nylon base (Ø 70 cm) or base with polished aluminium finish (Ø 68 cm), with 65 mm black or white braked-rubber castors. 5 armrests are available for the Black version: 20BRA fixed, 5BH 1D, 22BH 2D, 23BH 3D and 14BH 4D, and 2 armrests for the White version: 5BHW 1D, 22BHW 2D and 13BHW 3D.

Série opérateur proposée avec structure noire (N) ou blanche appelée White (BI-RAL 9010) avec dossier fixe (H 57 cm), version RETE (dossier en réssille) ou version AIR (muni d'une membrane composée d'une couche de mousse de 5 mm couplée à une réssille N, revêtue sur les deux faces). Disponible également avec appuie-tête réglable 2D (réglable en hauteur et en inclination, rembourré et tapissé avec carter de protection en Polypropylène). Support lombaire réglable sur 6 cm en hauteur CB-ADH noir ou CB-ADHW blanc ou réglable 2D (hauteur 6 cm et profondeur 15 mm) CB-ADH-2D noir ou CBADH-2DW blanc. Il est proposé avec 3 mécanismes de série: Synchro évolué SLYR2, Synchro SLY4 avec translation de l'assise et Contact permanent PCS4 avec réglage de tension. Vérin à gaz en CL4, piètement en Nylon Ø 70 cm noir ou blanc, ou en aluminium Ø 68 cm avec finition polie, roulettes freinées/souples de 65 mm noires ou blanches. Les accoudoirs proposés pour la version Black sont au nombre de 5: 20BRA fixe, 5BH 1D, 22BH 2D, 23BH 3D et 14BH 4D, tandis que pour la version White il y en a 2: 5BHW 1D, 22BHW 2D et 13BHW 3D.

Arbeitsstuhlreihe mit Gestell in schwarz (N) oder weiß mit der Bezeichnung White (BI-RAL 9010), fester Rückenlehne (H 57 cm) mit Netzbespannung (Rückenlehne) oder Air (mit Membran bestehend aus einer 5 mm starken Schaumstoffschicht und Netzbespannung N, beidseitig bezogen). Auch mit verstellbarer 2D-Kopfstütze erhältlich (höhen- und neigungsverstellbar, gefüllt und gepolstert mit Polypropylen-Schutzschale). 6 cm höhenverstellbare Lendenwirbelstütze CB-ADH schwarz oder CB-ADHW weiß bzw. verstellbare 2D-Kopfstütze (Höhe 6 cm und Tiefe 15 mm) CB-ADH-2D schwarz oder CBADH-2DW weiß. Drei Mechanismen werden standardmäßig angeboten: die weiterentwickelte Synchro-Version SLYR2, SLY4 mit Sitzflächenverschiebung und Permanentkontakt PCS4 mit Spannungsregulierung, Gaslift aus CL4, Sockel aus Nylon Ø 70 cm schwarz oder weiss oder aus Aluminium Ø 68 cm mit polierter Oberfläche, gebremste Rollen mit weichem Lauffring Ø 65 mm schwarz oder weiss. In der Version Black sind die Armlehnen in fünf Ausführungen erhältlich: 20BRA fest, 5BH 1D, 22BH 2D, 23BH 3D und 14BH 4D; in der Version White werden zwei Ausführungen angeboten: 5BHW 1D, 22BHW 2D und 13BHW 3D.

Base | Base | Piètement | Fußkreuz

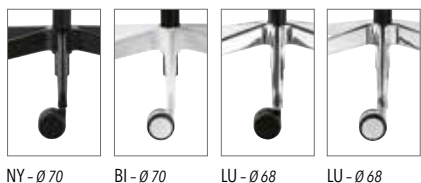

NY - Ø 70 BI - Ø 70 LU - Ø 68 LU - Ø 68

Rete | Mesh | Réssille | Netzbespannung

RETE N: 100% PES 330 gr/m2

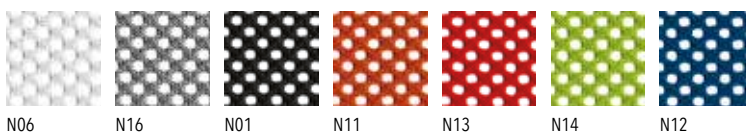

N06 N16 N01 N11 N13 N14 N12

Braccioli | Armrests | Accoudoirs | Armlehnen

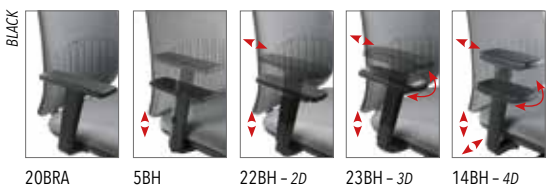

20BRA 5BH 22BH - 2D 23BH - 3D 14BH - 4D

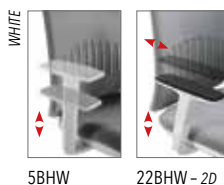

5BHW 22BHW - 2D

Schienale | Backrest | Réssille | Rückenlehne



RETE AIR

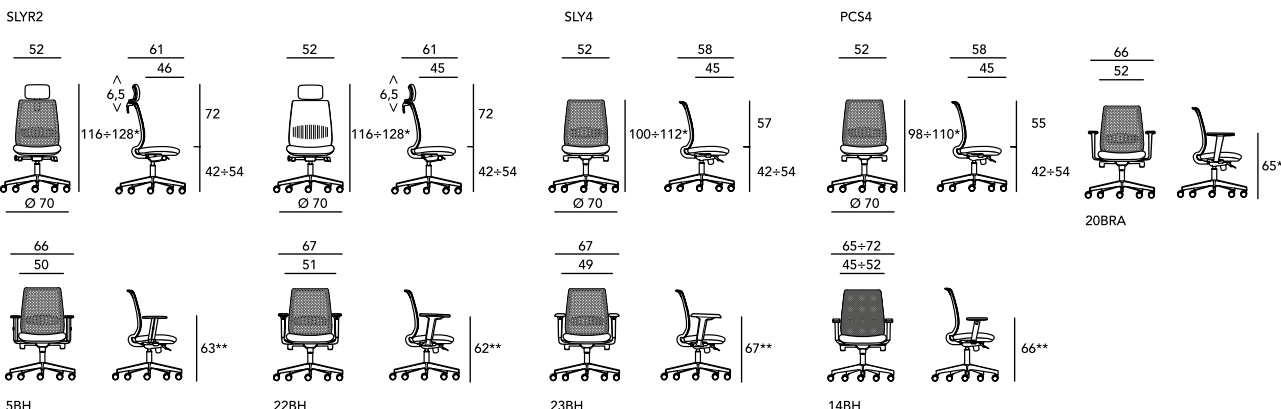

* misurata con poggiatesta abbassato | measured with lowered headrest | mesuré avec l'appui-tête abaissé | gemessen mit abgesenkter kopfstütze
 ** misurata con bracciolo abbassato | measured with lowered arm | mesuré avec accoudoir abaissé | gemessen mit abgesenkter armlehne

TASK

COBRA TT



Conforme al D.Lgs. 81/08 con prove EN 1335-1:2020/EN 1335-2:2018, tipologia B
 Conforms the EN 1335-1:2020/EN 1335-2:2018 standards, B class
 Conforme aux normes EN 1335-1:2020/EN 1335-2:2018, classe B
 Entsprechend der Richtlinien EN 1335-1:2020/EN 1335-2:2018, Klasse B



1/IM = Disponibile per alcuni rivestimenti a cartella
 Available for some covering only
 À disposition que pour quelque revêtement
 Erhältlich für einige Bezüge nach Stoff-Mustermappe

Serie operativa appartenente alla famiglia Cobra. Fronte dello schienale imbottito e tappezzato in ogni rivestimento a cartella. Disponibile con o senza poggiatesta 2D. La parte posteriore dello schienale è protetta da un carter in Polipropilene in colore nero. Regolazione in altezza dello schienale con sistema "Up&Down" (corsa 6 cm). Caratteristica peculiare di Cobra TT, è la conformazione ergonomica dello schienale, che permette all'operatore di essere a diretto contatto con il sostegno lombare favorendo una postura corretta.

Sono proposti 3 meccanismi di serie: Synchro evoluto SLYR2, Synchro SLY4 con traslazione del sedile e Contatto Permanente PCS4 con regolazione della tensione. Colonna a gas in CL4, base in Nylon Ø 70 cm nera oppure in alluminio Ø 68 cm con finitura lucida, ruote frenate/gommate da 65 mm.

I braccioli proposti sono 5: 20BRA fisso, 5BH 1D, 22BH 2D, 23BH 3D e 14BH 4D.

Task chair in the Cobra family. Front of padded backrest, upholstered with any of the standard coverings. Available with or without 2D headrest. The rear of the backrest is protected by a black Polypropylene shell. Height-adjustable backrest with "Up&Down" system (stroke: 6 cm). Special feature of Cobra TT is the ergonomic configuration of the backrest, which enables the operator to be in direct contact with the lumbar support, fostering correct posture.

3 standard mechanisms possible: Evolved Synchro SLYR2, Synchro SLY4 with seat slider, and PCS4 Permanent Contact with tension adjustment. Gas lift in CL4, black Nylon base (Ø 70 cm) or base with polished aluminium finish (Ø 68 cm), with 65 mm braked-rubber castors. 5 armrests to choose from: 20BRA fixed, 5BH 1D, 22BH 2D, 23BH 3D and 14BH 4D.

Série opératoire appartenant à la famille Cobra. Devant du dossier rembourré et tapissé dans tous les revêtements du catalogue. Disponible avec ou sans tête 2D. La partie arrière du dossier est protégée par un carter en Polypropylène de couleur noire. Réglage en hauteur du dossier avec système "Up&Down" (course 6 cm). Ce qui caractérise Cobra TT, c'est l'ergonomie du dossier, qui permet à l'opérateur d'être en contact direct avec le support lombaire, ce qui favorise une position correcte.

Il est proposé avec 3 mécanismes de série: Synchro évolué SLYR2, Synchro SLY4 avec translation de l'assise et Contact permanent PCS4 avec réglage de tension. Vérin à gaz en CL4, piètement en Nylon Ø 70 cm noir ou en aluminium Ø 68 cm avec finition polie, roulettes freinées/souples de 65 mm. Les accoudoirs proposés sont au nombre de 5: 20BRA fixe, 5BH 1D, 22BH 2D, 23BH 3D et 14BH 4D.

Arbeitsstuhlreihe aus der Cobra-Familie. Rückenlehne vorne gepolstert und mit allen Bezügen der Stoff-Mustermappe erhältlich. Mit oder ohne 2D-Kopfstütze lieferbar. Der hintere Teil der Rückenlehne ist mit einer schwarzen Polypropylen-schutzschale abgedeckt. Die Höhenverstellung der Rückenlehne erfolgt über Up-&-Down-System (Verstellweg 6 cm). Die Besonderheit von Cobra TT ist die ergonomische Gestaltung der Rückenlehne, die dem Nutzer einen direkten Kontakt mit der Lendenwirbelstütze ermöglicht und eine korrekte Sitzhaltung unterstützt.

Drei Mechanismen werden standardmäßig angeboten: die weiterentwickelte Synchro-Version SLYR2, SLY4 mit Sitzflächenverschiebung und Permanentkontakt PCS4 mit Spannungsregulierung. Gaslift aus CL4, Sockel aus Nylon Ø 70 cm schwarz oder Aluminium Ø 68 cm mit polierter Oberfläche, gebremste Rollen mit weichem Laufriem Ø 65 mm. Die Armlehnen werden in fünf Ausführungen angeboten: 20BRA fest, 5BH 1D, 22BH 2D, 23BH 3D und 14BH 4D.

Base | Base | Piètement | Fußkreuz

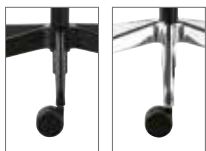

NY - Ø 70

LU - Ø 68

Braccioli | Armrests | Accoudoirs | Armlehnen

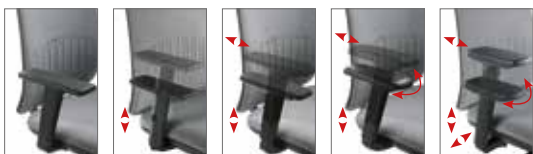

20BRA

5BH

22BH - 2D

23BH - 3D

14BH - 4D

SLYR2

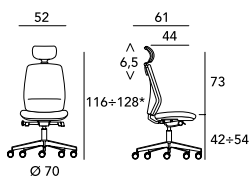

SLY4

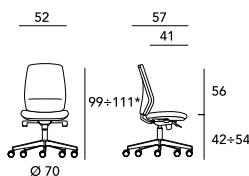

PCS4

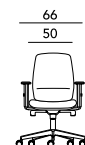
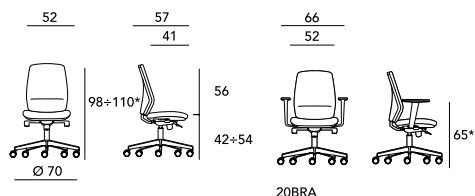

5BH



22BH



23BH

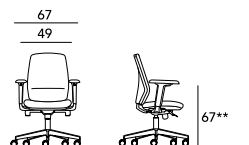

14BH

* misurata con poggiatesta abbassato | measured with lowered headrest | mesuré avec l'appui-tête abaissé | gemessen mit abgesenkter kopfstütze

** misurata con bracciolo abbassato | measured with lowered arm | mesuré avec accoudoir abaissé | gemessen mit abgesenkter armlehne



TASK

CO/22

rete/air



Conforme al D.Lgs. 81/08 con prove EN 1335-1:2020/EN 1335-2:2018, tipologia B
 Conforms the EN 1335-1:2020/EN 1335-2:2018 standards, B class
 Conforme aux normes EN 1335-1:2020/EN 1335-2:2018, classe B
 Entsprechend der Richtlinien EN 1335-1:2020/EN 1335-2:2018, Klasse B



1/IM = AIR Disponibile per alcuni rivestimenti a cartella RETE Rivestimenti King-Leder e rete nera N01
 Available for some covering only King-Leder coverings and black colour mesh N01
 À disposition que pour quelque revêtement Revêtements King-Leder et résille noire N01
 Erhältlich für einige Bezüge nach Stoff-Mustermappe Bezug King-Leder und schwarzes Netz N01

Serie operativa dotata di schienale regolabile in altezza (H 61 cm) proposta in 2 versioni: RETE (schienale in rete tipo "N" in 7 colori), AIR (schienale dotato di membrana composta da strato di gomma da 10 mm abbinata a rete "N", fronte schienale tappezzato, retro in rete colore standard nero). Proposta anche con poggiatesta regolabile 2D. Regolazione in altezza dello schienale con sistema "Up&Down" (corsa 7,5 cm). Supporto lombare regolabile in altezza integrato allo schienale (corsa 6 cm). Proposta con solo meccanismo Synchro evoluto SLYR2. Colonna a gas in CL4, base in Nylon Ø 70 cm nera, oppure in alluminio Ø 68 cm con finitura lucida, ruote frenate/gommate da 65 mm. I braccioli proposti sono 8: 8BRA fisso, 8BH 1D, 22BH 2D e 24BH 4D.

Task chair series with height-adjustable backrest (H 61 cm), in two variants: RETE (N-type mesh backrest available in 7 colours), AIR (backrest fitted with membrane formed of 10-mm thick foam layer combined with N-type mesh, upholstered backrest front, rear in standard black mesh). Also available with 2D adjustable headrest. Height-adjustable backrest with "Up&Down" system (stroke: 7,5 cm). Height-adjustable lumbar support integrated into backrest (stroke: 6 cm). Available only with the evolved Synchro SLYR2 mechanism. Gas lift in CL4, black Nylon base (Ø 70 cm) or base with polished aluminium finish (Ø 68 cm), with 65 mm braked-rubber castors. There are 4 armrests to choose from: 8BRA fixed, 8BH 1D, 22BH 2D and 24BH 4D.

Série opérateur équipée de dossier à hauteur réglable (H 61 cm) proposée en 2 versions: "RETE" (dossier en résille de type "N" en 7 couleurs), "AIR" (dossier muni d'une membrane composée d'une couche de mousse de 10 mm couplée à la résille "N", devant du dossier tapissé, derrière en résille de couleur standard noire). Proposée aussi avec tête réglable 2D. Réglage en hauteur du dossier avec système "Up&Down" (course 7,5 cm). Support lombaire réglable en hauteur intégré au dossier (course 6 cm). Proposée uniquement avec mécanisme Synchro évolué SLYR2. Vérin à gaz en CL4, piètement en Nylon Ø 70 cm noir, ou en aluminium Ø 68 cm avec finition polie, roulettes freinées/souples de 65 mm. Les accoudoirs proposés sont au nombre de 4: 8BRA fixe, 8BH 1D, 22BH 2D et 24BH 4D.

Arbeitsstuhlreihe mit höhenverstellbarer Rückenlehne (H 61 cm) in zwei Ausführungen: RETE (Rückenlehne mit Netzbespannung Typ "N" in 7 Farben), AIR (Rückenlehne mit Membran bestehend aus einer 10 mm starken Schaumstoffschicht mit Netzbespannung "N", vorne gepolstert, hinten mit Netzbespannung in der Standardfarbe schwarz). Auch mit verstellbarer 2D-Kopfstütze erhältlich. Die Höhenverstellung der Rückenlehne erfolgt über Up-&-Down-System (Verstellweg 7,5 cm). In die Rückenlehne integrierte höhenverstellbare Lendenwirbelstütze (Verstellweg 6 cm). Wird nur mit Synchro-Mechanismus in der weiterentwickelten Version SLYR2 angeboten. Gaslift aus CL4, Sockel aus Nylon Ø 70 cm schwarz oder Aluminium Ø 68 cm mit polierter Oberfläche, gebremste-Rollen mit weichem Laufring Ø 65 mm. Die Armlehnen werden in vier Ausführungen angeboten: 8BRA fest, 8BH 1D, 22BH 2D und 24BH 4D.

Base | Base | Piètement | Fußkreuz



NY - Ø 70

LU - Ø 68

Rete | Mesh | Résille | Netzbespannung

RETE N: 100% PES 330 gr/m2



N06

N16

N01

N11

N13

N14

N12

Braccioli | Armrests | Accoudoirs | Armlehnen

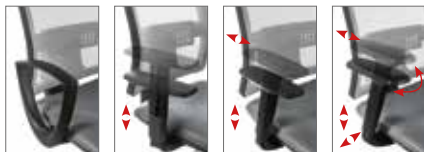

8BRA

8BH

22BH - 2D

24BH - 4D

Schienale | Backrest | Résille | Rückenlehne



RETE

AIR

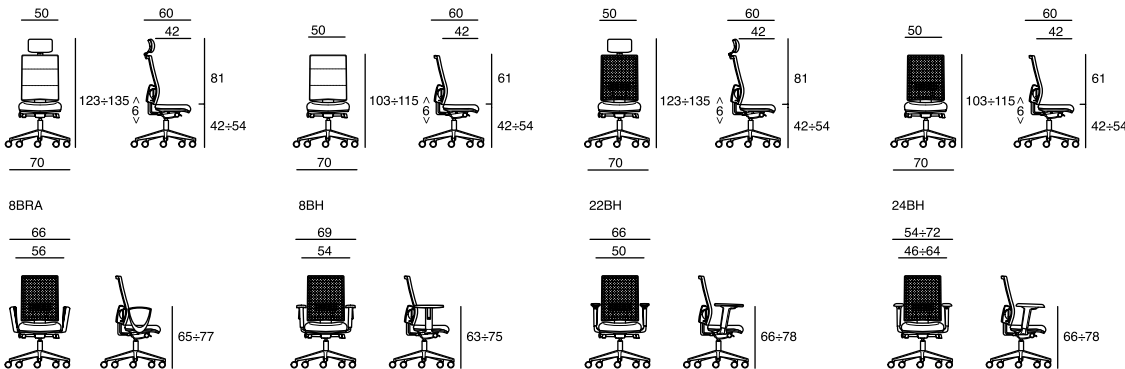



TASK

VIVA
rete/air



Conforme al D.Lgs. 81/08 con prove EN 1335-1:2020/EN 1335-2:2018, tipologia B
Conforms the EN 1335-1:2020/EN 1335-2:2018 standards, B class
Conforme aux normes EN 1335-1:2020/EN 1335-2:2018, classe B
Entsprechend der Richtlinien EN 1335-1:2020/EN 1335-2:2018, Klasse B



1/IM = AIR Disponibile per alcuni rivestimenti a cartella
Available for some covering only
À disposition que pour quelque revêtement
Erläutlich für einige Bezüge nach Stoff-Mustermappe

RETE Rivestimenti King-Leder e rete nera N01
King-Leder coverings and black colour mesh N01
Revêtements King-Leder et résille noire N01
Bezug King-Leder und schwarzes Netz N01

Serie operativa avente schienale (H 56 cm) proposto in due versioni: RETE (schienale in rete tipo "N" in 7 colori), AIR (schienale dotato di membrana composta da strato di gomma da 10 mm abbinata a rete "N", fronte schienale tappezzato, retro in rete colore standard nero). Regolazione 6 cm in altezza con sistema "Up&Down". Sono proposti 3 meccanismi di serie: Synchro evoluto SLYR2, Synchro SLY4 con traslazione del sedile e Contatto Permanente PCS4 con regolazione della tensione. Colonna a gas in CL4, base in Nylon Ø 68 cm nera oppure in alluminio con finitura lucida, ruote frenate/gommate da 65 mm. I braccioli proposti sono 5: 6BRA fisso, 8BRA fisso, 8BH 1D, 15BH-PU 2D e 10BH 3D.

Task chair series with backrest (H 56 cm), available in two versions: RETE (N-type mesh backrest available in 7 colours), AIR (backrest fitted with membrane formed of 10-mm thick layer of rubber combined with N-type mesh, upholstered backrest front, standard black mesh rear). Height-adjustable (6 cm) with "Up&Down" system. 3 standard mechanisms possible: Evolved Synchro SLYR2, Synchro SLY4 with seat slider, and PCS4 Permanent Contact with tension adjustment. Gas lift in CL4, black Nylon base (Ø 68 cm) or base with polished aluminium finish, with 65 mm braked-rubber castors. 5 armrests to choose from: 6BRA (fixed), 8BRA (fixed), 8BH (1D), 15BH-PU (2D) and 10BH (3D).

Série opérateur avec dossier (H 56 cm) proposé en deux versions: RETE (en résille type «N» en 7 couleurs), AIR (muni d'une membrane composée d'une couche de mousse de 10 mm couplée à une résille «N», face avant tapissée, face arrière en résille couleur standard noire). Réglage en hauteur de 6 cm avec système "Up&Down". La série est proposée avec 3 mécanismes de série: Synchro évolué SLYR2, Synchro SLY4 avec translation de l'assise et Contact permanent PCS4 avec réglage de la tension. Vérin à gaz en CL4, piètement en Nylon Ø 68 cm noir ou en aluminium avec finition polie, roulettes freinées/souples de 65 mm. Les accoudoirs proposés sont au nombre de 5: 6BRA fixe, 8BRA fixe, 8BH 1D, 15BH-PU 2D et 10BH 3D.

Arbeitsstuhlreihe mit 56 cm hoher Rückenlehne, angeboten in zwei Ausführungen: RETE (Rückenlehne mit Netzbespannung Typ «N» in 7 Farben), AIR (Rückenlehne mit Membran bestehend aus einer 10 mm starken Schaumstoffschicht mit Netzbespannung «N», vorne gepolstert, hinten mit Netzbespannung in der Standardfarbe schwarz). Über Up-&Down-System 6 cm höhenverstellbar. Drei Mechanismen werden standardmäßig angeboten: Die weiterentwickelte Synchro-Version SLYR2, SLY4 mit Sitzflächenverschiebung und Permanentkontakt PCS4 mit Spannungsregulierung. Gaslift KL4, Fußkreuz aus Nylon Ø 68 cm in schwarz oder aus poliertem Aluminium, gebremste Rollen mit weichem Laufring Ø 65 mm. Die Armlehnen werden in fünf Ausführungen angeboten: 6BRA fest, 8BRA fest, 8BH 1D, 15BH-PU 2D und 10BH 3D.

Base | Base | Piètement | Fußkreuz



NY - Ø 68 LU - Ø 68 CR N

Rete | Mesh | Résille | Netzbespannung

RETE N: 100% PES 330 gr/m2



N06 N16 N01 N11 N13 N14 N12

Braccioli | Armrests | Accoudoirs | Armlehnen



6BRA 8BRA 8BH 15BH-PU - 2D 10BH - 3D

Schienale | Backrest | Résille | Rückenlehne

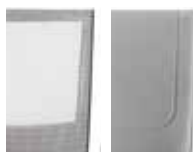

RETE AIR

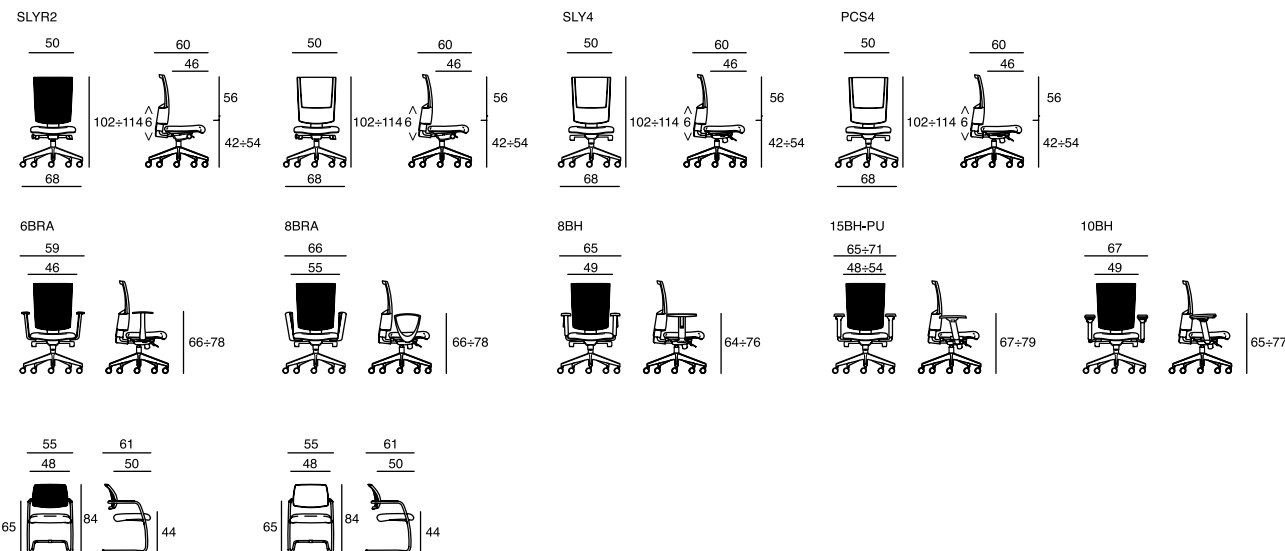



TASK

DATTILO GOLF 21

basic/plus



Conforme al D.Lgs. 81/08 con prove EN 1335-1:2020/EN 1335-2:2018, tipologia B
 Conforms the EN 1335-1:2020/EN 1335-2:2018 standards, B class
 Conforme aux normes EN 1335-1:2020/EN 1335-2:2018, classe B
 Entsprechend der Richtlinien EN 1335-1:2020/EN 1335-2:2018, Klasse B



1/IM = Disponibile per alcuni rivestimenti a cartella
 Available for some covering only
 À disposition que pour quelque revêtement
 Erhältlich für einige Bezüge nach Stoff-Mustermappe

Serie operativa proposta in due dimensioni: schienale H 48 cm, schienale H 40 cm. Entrambe le dimensioni sono disponibili in versione BASIC (imbottitura standard) e PLUS (imbottitura ergonomica, con gomma poliuretanic ignifuga in CL1).

Sono proposti 3 meccanismi di serie: Synchro evoluto SLYR2, Synchro SLY4 con traslazione del sedile, Contatto Permanente PCS4 con regolazione della tensione e Contatto Permanente PC.

Colonna a gas in CL4, base in Nylon Ø 68 cm nera oppure in alluminio con finitura lucida, ruote frenate/gommate da 50 mm. I braccioli proposti sono 5: 6BRA fisso, 8BRA fisso, 8BH 1D, 15BH-PU 2D e 10BH 3D.

Task series in two sizes: H 48 cm and H 40 cm. Both sizes are available in BASIC (standard padding) and PLUS (ergonomic padding, with CL1 fire-retardant Polyurethane).

3 standard mechanisms possible: Evolved Synchro SLYR2, Synchro SLY4 with seat slider, and PCS4 Permanent Contact with tension adjustment and PC Permanent Contact.

Gas lift in CL4, black Nylon base (Ø 68 cm) or base with polished aluminium finish, with 50 mm braked-rubber castors. 5 armrests to choose from: 6BRA (fixed), 8BRA (fixed), 8BH (1D), 15BH-PU (2D) and 10BH (3D).

Série opératrice proposée en deux dimensions: dossier H 48 cm, dossier H 40 cm. Les deux dimensions sont disponibles dans la version BASIC (rembourrage standard) et PLUS (rembourrage ergonomique, avec mousse de Polyuréthane ignifuge CL1).

La série est proposée avec 3 mécanismes de série: Synchro évolué SLYR2, Synchro SLY4 avec translation de l'assise, Contact Permanent PCS4 avec réglage de la tension et Contact Permanent PC.

Vérin à gaz en CL4, piètement en Nylon Ø 68 cm noir ou en aluminium avec finition polie, roulettes freinées/souples de 50 mm. Les accoudoirs proposés sont au nombre de 5: 6BRA fixe, 8BRA fixe, 8BH 1D, 15BH-PU 2D et 10BH 3D.

Arbeitsstuhlreihe mit zwei Rückenlehnenhöhen, H 48 cm und H 40 cm. Beide Größen sind in den Ausführungen BASIC (Standardpolsterung) und PLUS (ergonomische Polsterung, aus PU-Schaumstoff, feuerfest in KL1) erhältlich.

Drei Mechanismen werden standardmäßig angeboten: Die weiterentwickelte Synchro-Version SLYR2, SLY4 mit Sitzflächenverschiebung und Permanentkontakt PCS4 mit Spannungsregulierung und Permanentkontakt PC.

Gaslift KL4, Fußkreuz aus Nylon Ø 68 cm in schwarz oder aus poliertem Aluminium, gebremste Rollen mit weichem Laufriem Ø 50 mm. Die Armlehnen werden in fünf Ausführungen angeboten: 6BRA fest, 8BRA fest, 8BH 1D, 15BH-PU 2D und 10BH 3D.

Base | Base | Piètement | Fußkreuz



NY - Ø 68



LU - Ø 68



EL

Imbottitura | Padding | Rembourrage | Polsterung



BASIC



PLUS

Braccioli | Armrests | Accoudoirs | Armlehnen



6BRA



8BRA



8BH



15BH-PU - 2D

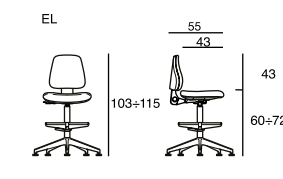
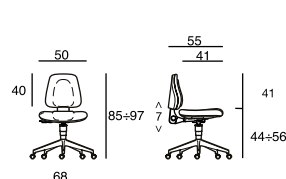
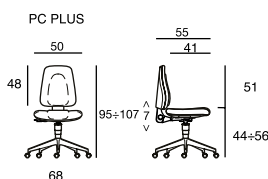
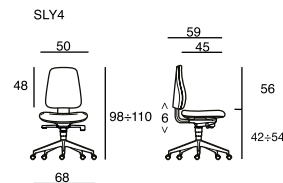
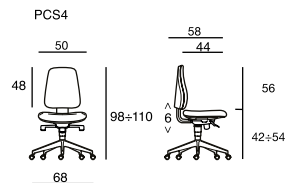
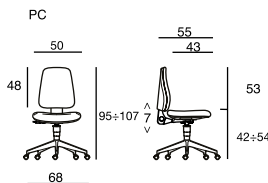

VISITORS / CONFERENCE

1000 PLUS



Conforme alla norma UNI EN 16139 livello 1
 Conforms the EN 16139 1st level standards
 Conforme aux normes EN 16139 1^{er} niveau
 Erfüllt die Anforderungen der Norm DIN EN 16139 Stufe 1



1/IM = Disponibile per alcuni rivestimenti a cartella
 Available for some covering only
 À disposition que pour quelque revêtement
 Erhältlich für einige Bezüge nach Stoff-Mustermappe

Serie polifunzionale per ospiti, riunioni e conferenza con versioni ad alta impilabilità. Monosocca in Polipropilene in abbinamento a vari tipi di strutture: 4 gambe con e senza braccioli o con scrittoio, base skid con e senza braccioli, sgabelli oppure su trave. Scocca disponibile in 5 colori: bianco, nero, antracite (disponibile in CL1 IT), oppure "GREEN" in materiale riciclato al 50%, rosso mattone e blu avio. Braccioli aperti proposti in 5 colori in abbinamento a scocca e struttura, oppure chiusi in colore nero, disponibili sia in Polipropilene che in alluminio quando con scrittoio. La struttura della versione a 4 gambe è proposta in 5 colori in abbinamento a scocca e braccioli, e anche con finitura cromata (CR). Pannello del sedile tappezzato applicabile al sedile (optional da fissare all'origine), disponibile nei rivestimenti a cartella.

Multipurpose series for visitors, meetings and conferences with easy stacking versions. Based on the Polypropylene shell in combination with different types of structures: 4-leg with or without armrests or with writing tablet, skid base with and without armrests, or on beam. Shell available in 5 colours: white, black, anthracite (available in fire-retardant CL1 IT), or "GREEN" in 50% recycled material, brick red and air force blue. Open armrests available in 5 colours to match the shell and structure, or closed armrests in black, available both in Polypropylene and in aluminium when with writing tablet. The structure finish of the 4-leg version is available in 5 colours matching shell and arms; a chrome finish (CR) is also available. An optional upholstered seat pad can be added to the seat (factory-mounted); available in listed coverings.

Série multifonctions pour visiteurs, réunions et conférence avec versions à haute empilabilité. Monoque en Polypropylène en combinaison avec différents types de structures: à 4 pieds avec ou sans accoudoirs ou avec tablette écriteire, piètement luge avec ou sans accoudoirs, tabouret ou sur poutre. Coque disponible en 5 couleurs: blanc, noir, anthracite (disponible en non feu CL1 IT), ou GREEN en matière recyclée à 50%, rouge brique et bleu aviation. Accoudoirs ouverts disponibles en 5 couleurs assorties à la coque et à la structure, ou accoudoirs fermés en noir, disponibles en Polypropylène et en aluminium dans la version avec tablette écriteire. La structure de la version à 4 pieds, en plus d'être proposée en 5 couleurs assorties à la coque et aux accoudoirs, est disponible également en finition chromée (CR). Panneau d'assise tapissé applicable sur l'assise (option à fixer à l'origine), disponible dans les revêtements de nuancier.

Mehrzweckstuhlreihe für Besucher, Meetings und Konferenzbereiche, Ausführungen mit hoher Stapelbarkeit. Sitzschale aus Polypropylen in Kombination mit verschiedenen Gestellausführungen: Vierfuß mit und ohne Armlehnen oder mit Schreibplatte, Kufengestell mit und ohne Armlehnen oder auf Traverse. Sitzschale in 5 Farben: weiß, schwarz, anthrazit (erhältlich in KL1-ITA), of "GREEN" van 50% recycled materiaal, ziegelrot und avio-blau. Armlehnen offen in 4 Farben passend zu Sitzschale und Gestell oder Ringarmlehnen in schwarz aus Polypropylen oder, bei Schreibplatte, aus Aluminium erhältlich. Das Vierfußgestell ist in 4 Farben passend zu Sitzschale und Armlehnen sowie verchromt (CR) lieferbar. Mit Polsteraufdoppelung für die Sitzfläche (optional, werkseitig montiert) mit allen Bezügen nach Stoff-Mustermappe erhältlich.

Struttura | Frame | Structure | Gestell

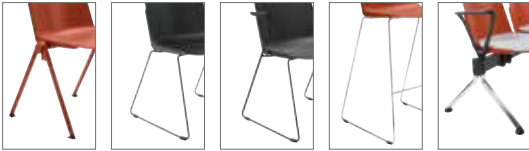

Braccioli | Armrests | Accoudoirs | Armlehnen



BRA/PLUS BRA/REVO-PP
 BRA/REVO-AL BRA/REVO-AL-TP

Finitura struttura | Frame finishing | Finition structure | Gestellausführung



N BI AN RM BL CR

Colori Polipropilene | Polypropylene colours | Couleurs Polypropylène | Polypropylen-Farben



NE00 BI05 AN57 RM30 BL60

"GREEN"
 Polipropilene riciclato al 50%.
 50% recycled Polypropylene.
 Polypropylène recyclé au 50%.
 Zu 50% recyceltes Polypropylen.
 ANG57

Versione ignifuga | Fire retardant version | Version ignifugée | Feuerfeste Ausführung: CL1 (Classe 1 IT)

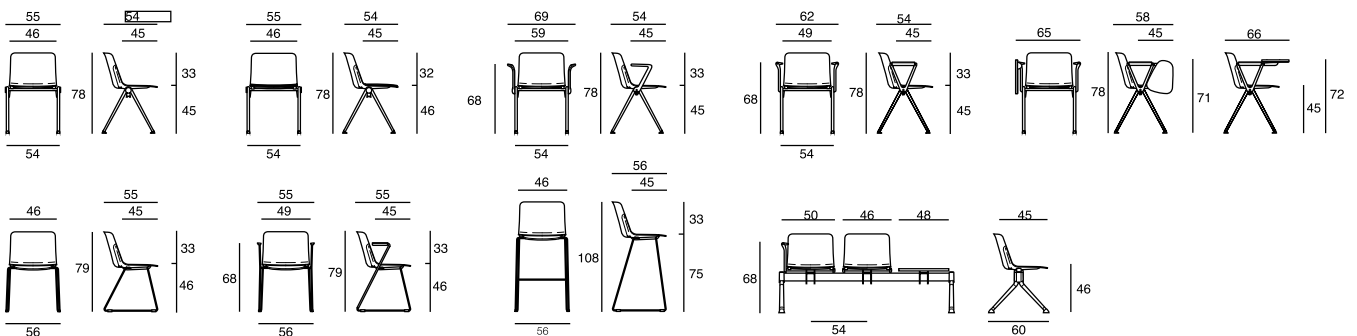



VISITORS / CONFERENCE

1000 REVO



Conforme alla norma UNI EN 16139 livello 1
 Conforms the EN 16139 1st level standards
 Conforme aux normes EN 16139 1^{er} niveau
 Erfüllt die Anforderungen der Norm DIN EN 16139 Stufe 1



1/IM = IM Disponibile per alcuni rivestimenti a cartella
 Available for some covering only
 À disposition que pour quelque revêtement
 Erhältlich für einige Bezüge nach Stoff-Musternappe

RETE Rivestimenti King-Leder e rete nera N01
 King-Leder coverings and black colour mesh N01
 Revêtements King-Leder et résille noire N01
 Bezug King-Leder und schwarzes Netz N01

Serie per ospiti o conferenza in versione a 4 gambe, anche con braccioli o scrittoio, oppure in versione su trave. La versione 4 gambe permette un'impilabilità elevata anche con braccioli o con scrittoio. È proposta in 3 varianti: "PP" sedile e schienale in Polipropilene in 8 colori, (di cui il nero disponibile in CL1 IT, oppure anche in versione "GREEN" in materiale riciclato al 50%); "IM" sedile tappezzato e schienale con pannello frontale tappezzato in abbinamento a plastiche nere, oppure "RETE" sedile tappezzato e schienale in rete di 7 colori in abbinamento a plastiche nere. Struttura 4 gambe proposta con finitura nera (N) o cromata (CR), disponibile con braccioli e poggiaabbraccia in Polipropilene, oppure con struttura del bracciolo in alluminio finitura nera e poggiaabbraccia in Polipropilene quando in versione con scrittoio. Nella versione panca, la trave e gli omega di fissaggio della seduta sono di colore nero, mentre le gambe autoportanti possono essere nere (N) o cromate (CR).

Range for visitors or conference areas. 4-leg chair with armrests or writing tablet, or beam-mounted. The 4-leg version has high stacking capability even with armrests or with writing tablet. It comes in three variants: "PP": Polypropylene seat and backrest in 8 colours (of which black is available in CL1 IT, or also in the "GREEN" version in 50% recycled material); "IM": upholstered seat and backrest with upholstered front panel to match black plastic parts; and "RETE": upholstered seat and mesh backrest in 7 colours to match black plastic parts. 4-leg frame with black (N) or chrome (CR) finish, available with Polypropylene armrests and arm pads, or with aluminium armrest (black finish) and Polypropylene arm pad for the version with writing tablet. In the beam-mounted version, the beam and the brackets bars for fastening the seat are black, while the freestanding legs come in black (N) or chrome (CR).

Série pour visiteurs ou conférence dans la version à 4 pieds, éventuellement avec accoudoirs ou tablette écriteiro, ou dans la version sur poutre. La version 4 pieds permet une empilabilité élevée même avec accoudoirs ou avec tablette écriteiro. Elle est proposée en 3 variantes: "PP" assise et dossier en Polypropylène en 8 coloris (dont le noir est disponible en CL1 IT, ou encore en version « GREEN » en matière recyclée à 50%); "IM" assise tapissée et dossier avec devant tapissé associé aux parties en plastique noir, ou "RETE" assise tapissée et dossier en résille en 7 coloris associé aux parties en plastique noir. Structure 4 pieds proposée avec finition noire (N) ou chromée (CR), disponible avec accoudoirs et manchettes en Polypropylène, ou avec structure de l'accoudoir en aluminium finition noire et manchettes en Polypropylène en cas de version avec tablette écriteiro. Dans la version banquette, la poutre et les omégas de fixation de l'assise sont de couleur noire, tandis que les pieds autoporteurs peuvent être noirs (N) ou chromés (CR).

Besucher- oder Konferenzserie mit 4-Fußgestell, auch mit Armlehnen, Schreibplatte oder auf Traverser. Die 4-Fuß-Version ermöglicht eine hohe Stapelbarkeit auch mit Armlehnen oder Schreibtabelle. Er wird in drei Varianten angeboten: "PP" Sitz und Rückenlehne aus Polypropylen in acht Farben (waarvan zwart verkrijgbaar is CL1 IT, of ook in de "GREEN" versie in 50% recycled materiaal); "IM" gepolsterter Sitz und Rückenlehne mit Polsteraufdoppelung passend zu schwarzem Kunststoff oder "RETE" gepolsterter Sitz und Netz-Rückenlehne in 7 Farben in Kombination mit schwarzem Kunststoff. 4-Fuß-Gestell in schwarzer (N) oder verchromter (CR) Ausführung, erhältlich mit Armlehnen und Armauflage aus Polypropylen oder mit Armlehnen aus Aluminium mit schwarzer Oberfläche und Armauflage aus Polypropylen in der Version mit Schreibplatte. Bei der Sitzbankversion sind die Traverser und die Befestigungsbügel der Sitzbefestigung schwarz, während das selbsttragende Gestell schwarz (N) oder verchromt (CR) sein kann.

Struttura | Frame | Structure | Gestell



Braccioli | Armrests | Accoudoirs | Armlehnen



BRA/REVO-PP BRA/REVO-AL

Finitura struttura | Frame finishing | Finition structure | Gestellausführung



N CR

Rete | Mesh | Résille | Netzbespannung

RETE N: 100% PES 330 gr/m2



N06 N16 N01 N11 N13 N14 N12

Colori Polipropilene | Polypropylene colours | Couleurs Polypropylène | Polypropylen-Farben



ST11 ST12 ST10 ST14 ST15 ST16 ST17 ST18



STG18



"GREEN" Polipropilene riciclato al 50%.
 50% recycled Polypropylene.
 Polypropylène recyclé au 50%.
 Zu 50% recyceltes Polypropylen.

Versione ignifuga | Fire retardant version | Version ignifugée | Feuerfeste Ausführung: CL1 (Classe 1 IT)

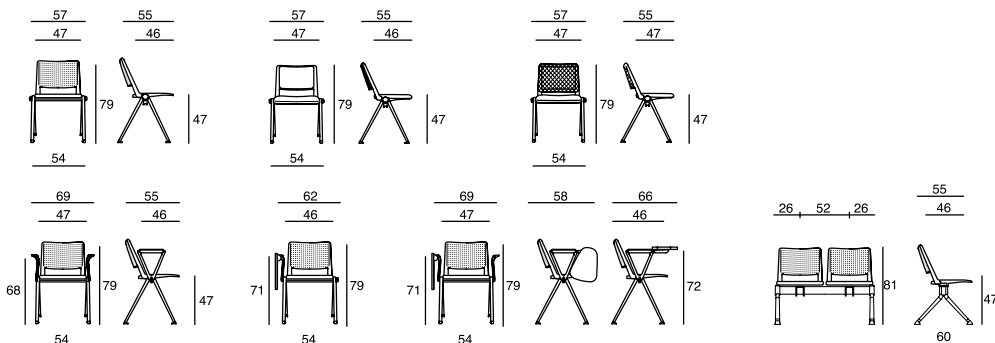

VISITORS / CONFERENCE

JX

Tests UNI EN 16139 livello 1
Tests EN 16139 1st level standards
Tests EN 16139 1^{er} niveau
Prüfungen nach EN 16139 Stufe 1

Serie polifunzionale a buona impilabilità per ospiti e riunioni proposta in due versioni: RETE (schienale in rete tipo "N" in 7 colori), AIR (schienale dotato di membrana composta da strato di gomma da 10 mm abbinata a rete "N", rivestita fronte/retro in ogni rivestimento a cartella).

Ogni versione è proposta con struttura a 4 gambe proposta verniciata nera (N) o cromata (CR) oppure con base skid con solo finitura cromata (CR). Disponibile con braccioli dotati di poggia-braccia in Polipropilene, oppure senza. La seduta (sedile e schienale) è in Polipropilene di colore nero. Il sedile può essere arricchito da un pannello tappezzato (da fissare all'origine).

Easy stacking multipurpose visitor and meeting chair series in two variants: RETE (N-type mesh backrest available in 7 colours), AIR (backrest fitted with membrane formed of 10-mm thick layer of rubber combined with N-type mesh, upholstered front and rear in every listed covering).

Each version is available with 4-leg structure with black (N) or chrome (CR) finish, or with skid base with chrome (CR) finish only. Available with or without Polypropylene armrests complete with arm pads. The seat and backrest are made from black Polypropylene. The series comes with or without upholstered seat pad (factory-mounted).

Série multifonctions à bonne empilabilité pour visiteurs et réunions proposée en deux versions: RETE (en résille type «N» en 7 couleurs), AIR (muni d'une membrane composée d'une couche de mousse de 10 mm couplée à une résille «N», tapissée sur les deux faces dans tous les revêtements du nuancier).

Chaque version est proposée avec la structure à 4 pieds laquée noire (N) ou chromée (CR) ou avec piètement luge uniquement dans la finition chromée (CR). Disponible avec accoudoirs munis ou pas de manchettes en Polypropylène. La partie siège (assise et dossier) est en Polypropylène de couleur noire. L'assise peut être complétée par un panneau tapissé (à fixer à l'origine).

Mehrzweckstuhltreihe mit guter Stapelbarkeit für Besucher- und Konferenzbereiche in zwei Ausführungen: RETE (Rückenlehne mit Netzbespannung Typ «N» in 7 Farben), AIR (Rückenlehne mit Membran bestehend aus einer 10 mm starken Schaumstoffschicht mit Netzbespannung „N“, beidseitig mit allen Bezügen nach Stoff-Mustermappe lieferbar).

Alle Ausführungen werden mit Vierfußgestell in schwarz (N) oder verchromt (CR) oder mit Kufengestell nur in der Ausführung verchromt (CR) angeboten. Mit oder ohne Armauflagen aus Polypropylen erhältlich. Sitz- und Rückenschale sind aus schwarzem Polypropylen. Auch mit Polsteraufdoppelung für die Sitzfläche (werkseitig montiert) lieferbar.

Struttura | Frame | Structure | Gestell**Braccioli | Armrests | Accoudoirs | Armlehnen****Schienale | Backrest | Résille | Rückenlehne**

RETE

AIR

Finitura struttura | Frame finishing | Finition structure | Gestellausführung

N

CR

Rete | Mesh | Résille | Netzbespannung

RETE N 100% PES 330 gr/m2



N06

N16

N01

N11

N13

N14

N12

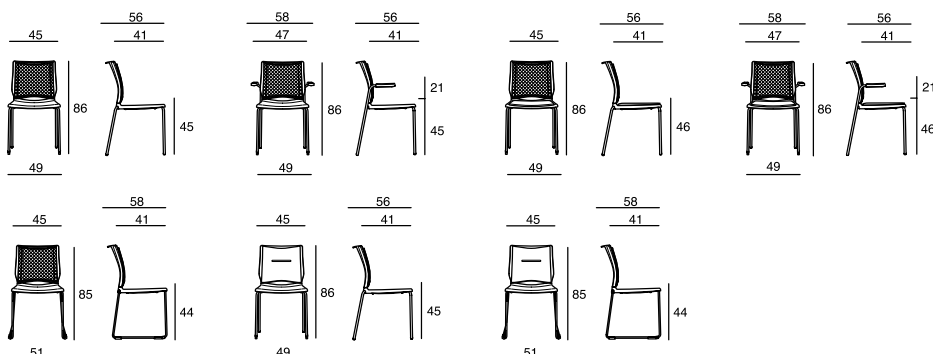



LOUNGE / WAITING

così



1/IM = Disponibile per alcuni rivestimenti a cartella
Available for some covering only
À disposition que pour quelque revêtement
Erhältlich für einige Bezüge nach Stoff-Mustermappe

Sedia caratterizzata dalla monoscocca dotata di braccioli integrati, proposta in 2 versioni: versione PP con scocca in Polipropilene disponibile in 7 colori (bianco, nero, blu, antracite, rosso matone, giallo senape e verde salvia) e versione IM, completamente rivestita in ogni rivestimento a cartella.

Le due versioni sono abbinata a diversi tipi di strutture fisse e girevoli. La base fissa a 4 gambe in Polipropilene, proposta in 7 colori, è abbinabile sia alla versione PP e sia alla versione IM, così come con tutte le strutture fisse e girevoli. Le varie versioni non sono impilabili.

Chair characterized by a seat shell conceived with integrated armrests proposed in 2 versions: PP version with Polypropylene shell available in 7 colors (white, black, blue, anthracite, brick red, mustard yellow and sage green) and IM version, completely upholstered shell.

The two versions are combined with different types of fixed and swivel frames. The fixed 4-legged Polypropylene base, available in 7 colors, can be combined with both the PP and IM versions, as well as all the fixed and swivel frames. All versions are not stackable.

Chaise caractérisée par une coque équipée d'accoudoirs intégrés proposée en 2 versions: version PP avec coque en Polypropylène disponible en 7 couleurs (blanc, noir, bleu, anthracite, rouge brique, jaune moutarde et vert sauge) et version IM, coque entièrement habillée.

Les deux versions sont combinées avec différents types de structures fixes et pivotantes. La structure fixe à 4 pieds en Polypropylène, disponible en 7 couleurs, peut être combinée avec les versions PP et IM, ainsi que toutes les structures fixes et pivotantes. Toutes les versions ne sont pas empilables.

Dieser Stuhl zeichnet sich durch eine einteilige Sitzschale mit integrierten Armlehnen aus und ist in 2 Ausführungen erhältlich: Version PP mit Sitzschale aus Polypropylen in 7 Farben (weiß, schwarz, blau, anthrazit, ziegelrot, senfegelb und salbeigrün) und Version IM, vollständig bezogen mit allen Bezügen nach Stoff-Mustermappe.

Beide Versionen sind mit verschiedenen Gestellausführungen, fest oder drehbar, lieferbar. Das in 7 Farben erhältliche Vierfüßgestell aus Polypropylen kann, ebenso wie alle festen und drehbaren Gestellausführungen, mit den Versionen PP und IM kombiniert werden. Die verschiedenen Versionen sind nicht stapelbar.

Scocca | Shell | Coque | Schale



PP

IM

Struttura | Frame | Structure | Gestell

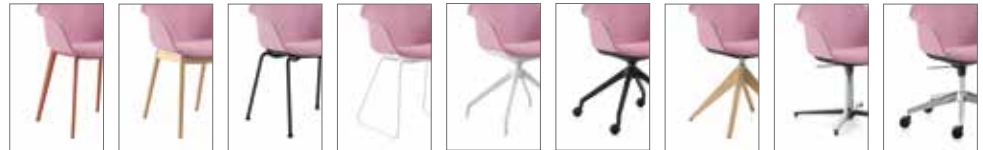

Finitura legno | Wood finish | Finition bois | HolzAusführung



F
faggio naturale
natural beech
hêtre naturel
Buche natur



Colori Polipropilene scocca e base 4 gambe | Polypropylene shell colours and 4-legged bases | Couleurs coque et structure à 4 pieds en Polypropylène | Polypropylenfarben der Schale und Vierbeingestell



B116

NE17

AN11

RM32

BL09

VS12

GS39

PP - 4GP

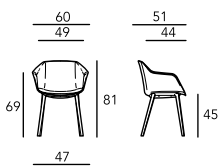

IM - 4GW

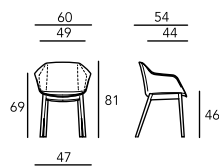

IM - 4GM

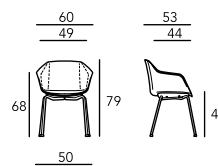

IM - SKID

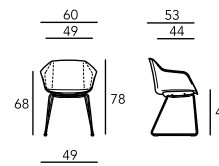

IM - 4GIR W

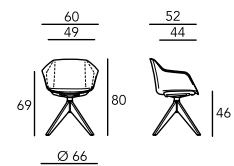

IM - 4GP

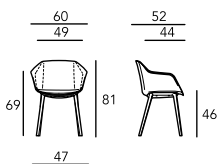

IM - 4GIR NY PIED

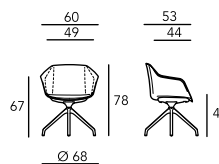

IM - 4GIR NY ROU

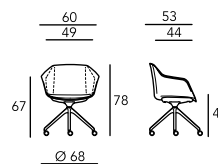

IM - 4GIR ALU

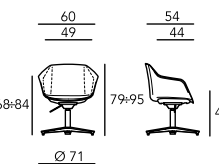

IM - 5GIR ALU

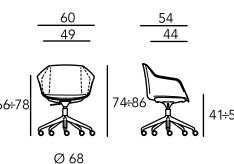

LOUNGE / WAITING

GEMMA

Tests UNI EN 16139 livello 1
 Tests EN 16139 1st level standards
 Tests EN 16139 1^o niveau
 Prüfungen nach EN 16139 Stufe 1



1/IM = Disponibile per alcuni rivestimenti a cartella
 Available for some covering only
 À disposition que pour quelque revêtement
 Erhältlich für einige Bezüge nach Stoff-Mustermappe

Poltroncina polifunzionale con braccioli integrati adatta per attesa, ospiti o riunioni.

Scocca in Polipropilene (100% vergine) in 3 colori (nero, grigio e bianco), caratterizzata dallo schienale microforato con disegno quadrato. Sedile imbottito con gomma poliuretanic schiumata ignifuga CL1 di spessore generoso che conferisce un elevato confort di seduta e può essere tappezzato in ogni rivestimento a cartella.

Proposta fissa con base a 4 gambe o su slitta entrambe con finitura colore nero (N), cromata (CR) o verniciata bianca (BI). Solo girevole con base Spider in Nylon di colore nero o bianco oppure girevole ed elevabile con base Spider in alluminio finitura nera (N) o lucida (LU). Base a 5 razze, anche proposta in versione sgabello, girevole ed elevabile proposta solo con finitura lucida (LU). Le sedie fisse dispongono di un carter sotto il sedile per facilitarne l'impilabilità.

Multipurpose lounge chair with integrated armrests suitable for waiting rooms, visitors or meetings.

100% virgin Polypropylene shell in 3 colours (black, grey and white), distinguished by the micro-perforated backrest with square pattern. The seat is padded with CL1 fire retardant polyurethane, generously thick for added seating comfort, and it can be upholstered with any of the listed coverings.

Fixed option with 4-leg or sled base, both with black (N), chrome (CR) or white coated (BI) finish. Swivel only with black or white spider base, or swivel and height-adjustable with aluminium spider base in black (N) or polished (LU) finish. 5-star base, also in stool version, swivel and height-adjustable, available with polished (LU) finish only. The fixed chairs have casing under the seat to make stacking easier.

Petit fauteuil multifonctions avec accoudoirs intégrés, adapté pour attente, visiteurs ou réunions.

Coque en polypropylène (100% vierge) en 3 couleurs (noir, gris et blanc), caractérisée par le dossier microperforé avec motif carré. Assise rembourrée en mousse de polyuréthane ignifuge CL1 épaisse assurant un grand confort et tapissable dans tous les revêtements du nuancier.

Proposé dans la version fixe à 4 pieds ou sur piètement luge, toutes deux avec finition de couleur noire (N), chromée (CR) ou laquée blanche (BI). Fauteuil uniquement pivotant avec piètement «spider» en Nylon noir ou blanc ou pivotant et réglable en hauteur avec piètement «spider» en aluminium finition noire (N) ou polie (LU). Piètement à 5 branches, proposé également dans la version tabouret, pivotant et réglable en hauteur, uniquement dans la version polie (LU). Les chaises fixes disposent d'un carter sous l'assise pour faciliter l'empilabilité.

Mehrzwecksessel mit integrierten Armlehnen für Besucher-, Konferenz- und Wartebereiche.

Sitzschale aus Polypropylen (100% Reinmaterial) in 3 Farben lieferbar (schwarz, grau und weiß), durch die mikroperforierte Rückenlehne mit quadratischem Muster gekennzeichnet. Der Polstersitz aus PU-Schaum, feuerfest Klasse 1, von großzügiger Dicke, sorgt für hohen Sitzkomfort und ist mit allen Bezügen der Stoff-Mustermappe erhältlich.

Als Vierfußmodell oder Freischwinger angeboten, beide in den Ausführungen schwarz (N), verchromt (CR) oder weiß lackiert (BI). Nur als Drehsessel mit Sternfuß aus schwarzem oder weißem Nylon oder als höhenverstellbarer Drehsessel mit Sternfuß aus Aluminium in den Ausführungen schwarz (N) oder poliert (LU). 5-Stern-Fußkreuz, auch als dreh- und höhenverstellbarer Hocker nur in der Ausführung poliert (LU) erhältlich. Für die Stapelbarkeit der Stühle mit festem Gestell sorgt eine spezielle Unterschale.

Struttura | Frame | Structure | Gestell

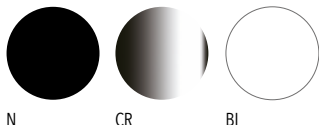
Finitura struttura fissa | Fixed frame finishing | Finition structure fixe | Gestellausführung

N CR BI

Colori Polipropilene | Polypropylene colours | Couleurs Polypropylène | Polypropylen-Farben

GE/BI GE/GR GE/NE

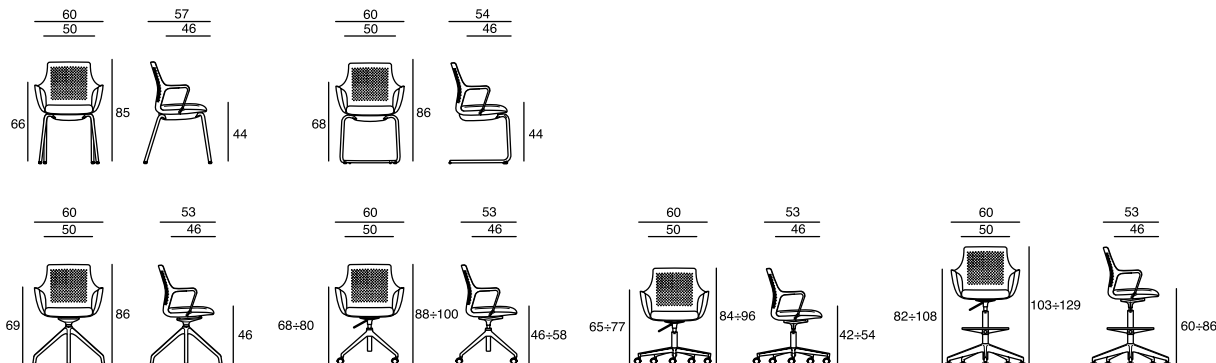



LOUNGE / WAITING

DOLLY



1/IM = Disponibile per alcuni rivestimenti a cartella
 Available for some covering only
 À disposition que pour quelque revêtement
 Erhältlich für einige Bezüge nach Stoff-Mustermappe

Poltroncina polifunzionale completamente rivestita con braccioli integrati; adatta per attesa, ospiti o riunioni. L'imbottito è costituito da due parti distinte poi unite tra loro mediante viti: il sedile con interno in multistrato di faggio imbottito con gomma poliuretano e lo schienale in multistrato di faggio curvato con i braccioli integrati, imbottito sia all'interno che all'esterno con schiumato poliuretano. Sedile e schienale possono essere tappezzati anche in colori o in rivestimenti diversi purché siano nella stessa categoria.

Proposta fissa con base a slitta Ø 25 mm nelle finiture nera (N), cromata (CR) o bianca (BI - RAL 9010), oppure solo girevole con base Spider in Nylon di colore nero o bianco oppure girevole ed elevabile con base a 5 razze, proposta con finitura lucida (LU) o verniciata nera (N).

Fully upholstered multipurpose lounge chair with integrated armrests suitable for waiting rooms, visitors or meetings. The upholstery consists of two separate parts that are screwed together: the seat with beech plywood inner padded with polyurethane and the backrest in curved beech plywood with integrated armrests, padded both inside and out with polyurethane foam. Seat and backrest can be upholstered in different colours and coverings as long as these are in the same category.

Fixed option with Ø 25 mm sled base in black (N), chrome (CR) or white (BI - RAL 9010) finish, or swivel only with black or white Nylon spider base, or swivel and height-adjustable with 5-star base, available with polished (LU) or black (N) coated finish.

Petit fauteuil multifonctions entièrement revêtu avec accoudoirs intégrés; adapté pour attente, visiteurs ou réunions. Le siège rembourré est constitué de deux parties distinctes assemblées entre elles par des vis: l'assise avec âme en multiplis de hêtre, rembourrée de mousse de polyuréthane et le dossier en multiplis de hêtre courbé avec les accoudoirs intégrés, rembourré de mousse de polyuréthane aussi bien à l'intérieur qu'à l'extérieur. L'assise et le dossier peuvent être tapissés également dans des couleurs ou des revêtements différents à condition d'appartenir à la même catégorie.

Proposé dans la version fixe sur piètement luge Ø 25 mm dans les finitions noire (N), chromée (CR) ou blanche (BI - RAL 9010), ou uniquement pivotant avec piètement «spider» en Nylon noir ou blanc ou pivotant et réglable en hauteur avec piètement à 5 branches, dans la finition polie (LU) ou laquée noire (N).

Mehrzwecksessel, vollständig bezogen, mit integrierten Armlehnen für Besucher-, Konferenz- und Wartebereiche. Der Polstersessel besteht aus zwei getrennten Teilen, die dann mit Schrauben zusammengefügt werden: der Sitz mit einer Innenseite aus Buchenschichtholz, gepolstert mit PU-Schaumstoff, und die Rückenlehne aus gebogenem Buchenschichtholz mit integrierten Armlehnen, innen und außen mit Polyurethanschaumstoff gepolstert. Sitz und Rückenlehne können auch in unterschiedlichen Farben und mit verschiedenen Bezügen geliefert werden, die jedoch der gleichen Kategorie angehören müssen. In der festen Version als Freischwinger Ø 25 mm in den Ausführungen schwarz (N), verchromt (CR) oder weiß (BI - RAL 9010), oder nur als Drehsessel mit Sternfuß aus Nylon in schwarz oder weiß oder als höhenverstellbarer Drehsessel mit 5-Stern-Fußkreuz in polierter (LU) oder schwarz lackierter (N) Ausführung.

Struttura | Frame | Structure | Gestell

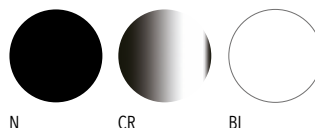
Finitura struttura fissa | Fixed frame finish |
Finition structure fixe | Gestellausführung

N CR BI

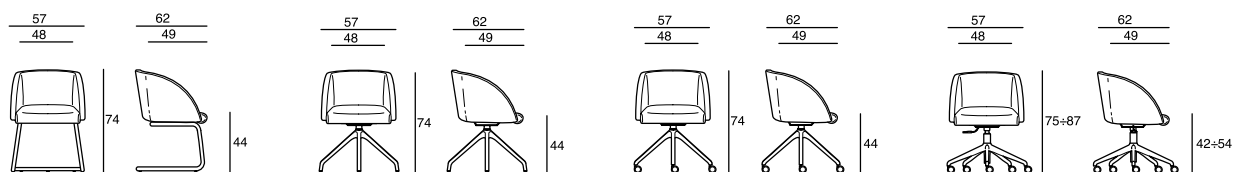

LOUNGE / WAITING

KEN



1/IM = Disponibile per alcuni rivestimenti a cartella
Available for some covering only
À disposition que pour quelque revêtement
Erhältlich für einige Bezüge nach Stoff-Mustermappe

Serie monomaterica realizzate in Polipropilene anti "UV", utilizzabile anche all'esterno, proposta in tre versioni: a 4 gambe con e senza braccioli e sgabello H 75 cm.

Disponibile in 6 colori: bianco, azzurro, verde, cipria, rosso e grigio riciclato al 100%.

Pannello del sedile tappezzato applicabile al sedile della sedia nei rivestimenti a cartella o nel rivestimento specifico per "outdoor" LEV (il pannello si fissa all'origine, non è disponibile per versione sgabello).

Single-material series made of anti-UV Polypropylene, which can also be used outdoors, available in three versions: 4-legged with and without armrests and stool H 75 cm.

Available in 6 colours: white, light blue, green, powder, red and gray 100% recycled.

Upholstered seat panel applicable to the seat of the chair in the covering available in our card or in the specific fabric for "outdoor" ref. LEV (the panel must be fixed at the origin, not available for the stool version).

Série monomatière en Poly-propylène anti-UV, utilisable également en extérieur, disponible en trois versions: 4 pieds avec et sans accoudoirs et tabouret H 75 cm.

Disponibile en 6 coloris: blanc, bleu clair, vert, rose poudré, rouge et gris 100% recyclé.

Panneau d'assise rembourré applicable à l'assise de la chaise dans les revêtements du nuancier ou bien dans le tissu LEV, spécifique pour l'outdoor (placet à fixer à l'origine, non disponible pour la version tabouret).

Monomaterial-Reihe aus UV-beständigem Polypropylen, auch im Außenbereich verwendbar und in drei Ausführungen erhältlich: als Vierfußmodell mit oder ohne Armlehnen sowie als Hocker H 75 cm.

In 6 Farben lieferbar: weiß, hellblau, grün, puderosa, rot und grau 100% recycelt. Polsteraufdoppelung für die Sitzfläche mit allen Bezügen nach Stoff-Mustermappe oder speziellem "Outdoor"-Bezug LEV (werkseitig montiert, nicht erhältlich für die Hockerausführung).

Scocca | Shell | Coque | Schale



Op. PAD/SED



PP Colori Polipropilene | Polypropylene colours | Couleurs du Polypropylène | Polypropylenfarben



K01



K02



K03



K04



K05



K06

"GREEN" ♻️

Polipropilene riciclato al 100%.
100% recycled Polypropylene.
Polypropylène recyclé au 100%.
Zu 100% recyceltes Polypropylen.

Rivestimenti Outdoor | Outdoor coverings | Revêtement extérieurs | Outdoor-Bezug

LEV

100% PES RECYCLED
WATER-REPELLENT
ANTI UV



Altezza | Height | Hauteur | Höhe: **H 145 cm**
Peso | Weight | Poids | Gewicht: **245 gr/m²**
Martindale: **100.000 cicli/turns/cycles/Zyklen**

Test Produttore | Manufacturers Tests |
Tests du Fabricant | Test Produttore
I = **1/IM (UNI 9175)** USA = TBC California117
EN 1021/1-2 (flame and cigarette tests)



EV08



EV02



EV01



EV05



EV03



EV07



EV06

L'imbottitura del sedile con tessuto LEV per outdoor è realizzata con materassino in Polietilene; il sedile della sedia viene opportunamente forato per permettere il drenaggio dell'acqua.

The seat padding with LEV outdoor fabric is made with a Polyethylene mattress; the seat of the chair is appropriately perforated to allow water drainage.

Le rembourrage du siège en tissu extérieur LEV est constitué d'un matelas en Polyéthylène; le siège de la chaise est perforé de manière appropriée pour permettre l'évacuation de l'eau.

Die Sitzpolsterung mit LEV-Bezug für den Outdoor-Bereich besteht aus einer Polyethylen-Einlage; die Sitzschale des Stuhls ist mit Bohrungen für den Wasserablauf ausgestattet.

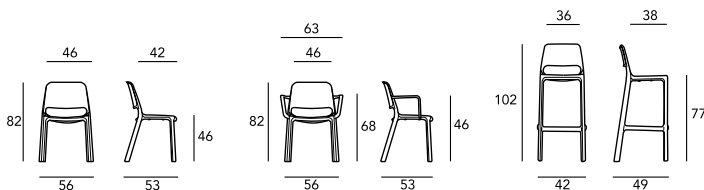



LOUNGE / WAITING

BOY



1/IM = Disponibile per alcuni rivestimenti a cartella
Available for some covering only
À disposition que pour quelque revêtement
Erhältlich für einige Bezüge nach Stoff-Mustermappe

Le due tipologie di sgabello della serie BOY (alto h 75 cm e basso h 46 cm) sono entrambe proposte con quattro gambe in massello di faggio avente finitura naturale. L'imbottito del sedile è in schiumato poliuretano, interno sedile in ABS e struttura sedile in Nylon caricato fibra vetro costituiscono gli elementi che si accoppiano alle gambe in legno massello con finitura naturale di BOY.

La struttura del sedile può essere proposta in due colori: bianco (RAL 9016) e antracite (RAL 7011) in abbinamento al colore del poggiatesta in Nylon applicato alle gambe dello sgabello h 75 cm.

Il sedile può essere rivestito in ogni rivestimento a cartella.

The two stool types in the BOY range (high: h 75 cm and low: h 46 cm) both come with four solid beech legs with a natural finish. The seat padding in Polyurethane foam, with ABS inner insert, and the Nylon frame reinforced with glass fibre are coupled with the solid beech legs with a natural finish of BOY.

The seat frame is available in two colours: white (RAL 9016) and anthracite (RAL 7011), matching the colour of the Nylon footrest attached to the legs (h 75 cm stool).

The seat can be upholstered with any of the listed coverings.

Les deux types de tabouret de la série BOY (haut h 75 cm et bas h 46 cm) sont les deux propositions à quatre pieds en hêtre massif avec finition naturelle. Le rembourrage de l'assise en mousse Polyuréthane avec l'intérieur en ABS et la structure en Nylon renforcé de fibre de verre, constituent les éléments qui s'unissent aux pieds en bois massif finition naturelle de BOY.

La structure de l'assise est proposée en deux couleurs: blanc (RAL 9016) et anthracite (RAL 7011), en association avec la couleur du repose-pieds en Nylon appliqué aux pieds du tabouret h 75 cm. L'assise peut être revêtue avec tous les revêtements du nuancier.

Die beiden Hockermodelle der Serie BOY (hoch h 75 cm und niedrig h 46 cm) werden mit vier Beinen aus massiver Buche in Naturholzausführung angeboten. Die Sitzpolsterung aus Polyurethanschaumstoff mit Innenmaterial aus ABS-Kunststoff und der Rahmen aus glasfaserverstärktem Nylon verbinden sich perfekt mit den naturfarbenen Massivholzbeinen von BOY.

Der Sitzrahmen ist in zwei Farben erhältlich: weiß (RAL 9016) und anthrazit (RAL 7011), passend zur Farbe der Nylon-Fußstütze des 75 cm hohen Hockers.

Die Sitzfläche kann mit allen Bezügen nach Stoff-Mustermappe bezogen werden.

Struttura | Frame | Structure | Gestell



Finitura legno | Wood finish | Finition bois | Holzausführung



F
faggio naturale
natural colour
couleur naturelle
Buche Natur

Colori Nylon per struttura e poggiatesta | Nylon colours for frame and footrest | Couleurs Nylon pour structure et repose-pieds | Nylonfarben für Rahmen und Fußstütze



AN11

BI16

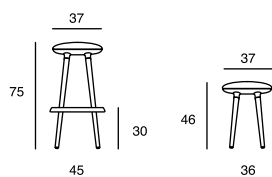

LOUNGE / WAITING

MITO



1/IM = Disponibile per alcuni rivestimenti a cartella
 Available for some covering only
 À disposition que pour quelque revêtement
 Erhältlich für einige Bezüge nach Stoff-Mustermappe

Poltrona, divani a 2 e 3 posti e panche con intelaiatura portante in legno d'abete, rivestita con pannelli in agglomerato ligneo. I braccioli imbottiti sono in continuità con lo schienale e sono leggermente inclinati per favorire il confort all'appoggio delle braccia. Alla struttura in abete sono poi applicati degli strati differenti di gomma poliuretana con spessori e densità differenti in base alla posizione.

Il rivestimento è costituito da un'unica fodera cucita e calzata sull'imbottitura e poi fissata con punti metallici. La tappezzeria può essere valorizzata dalla possibilità di applicare un elegante profilo in finta pelle Leder Vega che corre lungo il profilo esterno dello schienale per poi congiungersi con i braccioli e il fronte del sedile. Divani, panche e tavolini sono proposti con 4 piedi realizzati in acciaio cromato (CR), oppure con finitura nera (N) o bianca (BI), dotati di scivoli in plastica adatti a ogni tipo di pavimento.

Easy chair, 2- and 3-seater sofas and benches with spruce wood framework, covered with engineered wood panels. The padded armrests are integrated into the backrest and are slightly tilted so arms can rest comfortably. The spruce structure is then covered with a number of layers of polyurethane with different thicknesses and densities based on the position.

The covering consists of a single stitched cover fitted onto the padding, then secured with staples. The upholstery can be further refined by adding an elegant Leder Vega imitation leather trim that runs along the outer edge of the backrest and then connects with the armrests and the front of the seat. Sofas, benches and side tables come with four feet made from chrome (CR) steel, or with black (N) or white (BI) finish, fitted with plastic glides and suitable for all floor surfaces.

Fauteuil, canapés 2 et 3 places et banquettes avec châssis portant en bois de sapin, recouvert de panneaux en bois aggloméré. Les accoudoirs rembourrés créent une ligne continue avec le dossier et sont légèrement inclinés pour rendre l'appui des bras plus confortable. Plusieurs couches de mousse de polyuréthane de différentes épaisseurs et densités sont ensuite appliquées sur la structure en sapin.

Le revêtement est constitué d'une housse unique cousue et enfilée sur le rembourrage puis fixée avec des agrafes métalliques. Le revêtement peut être mis en valeur par l'application d'un élégant profil en simili cuir Leder Vega qui suit le bord extérieur du dossier puis rejoint les accoudoirs et le devant de l'assise. Les canapés, les banquettes et les tables basses sont proposés avec 4 pieds réalisés en acier chromé (CR), ou avec finition noire (N) ou blanche (BI), munis de patins en plastique adaptés à tous les sols.

Sessel, Zwei- und Dreisitzersofas und Bänke mit Gestell aus Fichtenholz, verkleidet mit Holzwerkstoffplatten. Die gepolsterten Armlehnen bilden einen fließenden Übergang mit der Rückenlehne und sind für eine komfortable Armablage leicht geneigt. Auf die Struktur aus Fichtenholz werden dann verschiedene Schichten aus PU-Schaum mit je nach Position unterschiedlichen Dicken und Dichten aufgebracht.

Der Bezug ist einteilig, wird auf die Polsterung genäht und aufgezogen und dann mit Metallstiften befestigt. Der Bezug kann mit einem eleganten Keder aus Kunstleder Leder Vega veredelt werden, der an der Außenkante der Rückenlehne entlang über die Armlehnen bis hin zur Vorderseite des Sitzes verläuft. Sofas, Bänke und Tische sind mit 4 Stahlfüßen in den Ausführungen verchromt (CR), schwarz (N) oder weiß (BI) sowie mit Kunststoffgleitern für alle Böden ausgestattet.

Piedi in acciaio | Steel feet | Pieds en acier | Stahlfüße



Finitura piedi | Feet finish | Finition pieds | Füße ferling

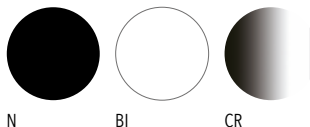

Profilo di rifinitura | Finishing profile | Profil de finition | Abschlussprofil



op. Profilo di rifinitura in finta pelle | Imitation leather finishing profile | Profil de finition en similicuir | Abschlussprofil aus Kunstleder

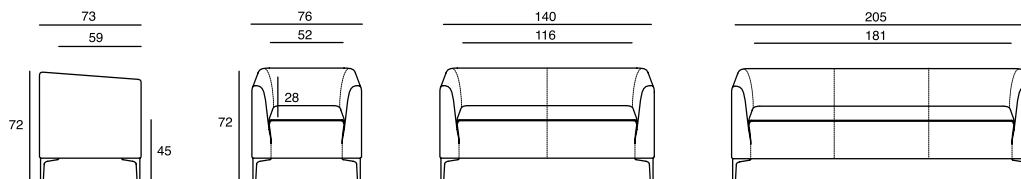
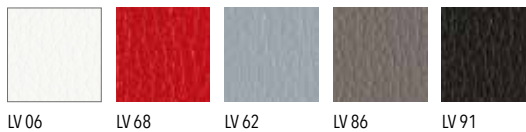



LOUNGE / WAITING

TAGO



1/IM = Disponibile per alcuni rivestimenti a cartella
Available for some covering only
À disposition que pour quelque revêtement
Erhältlich für einige Bezüge nach Stoff-Mustermappe

Poltrona, divani a 2 e 3 posti e panche con intelaiatura portante in legno d'abete, rivestita con pannelli in agglomerato ligneo. Le cinghie elastiche poste sul sedile garantiscono la corretta portanza della seduta. Alla struttura in abete sono poi applicati degli strati differenti di gomma poliuretana con spessori e densità differenti in base alla posizione cuscini del sedile e dello schienale sono amovibili e sono imbottiti con gomma poliuretana indeformabile spessore abbondanti per garantirne la comodità.

La tappezzeria è calzata sull'inserto ligneo preparato con l'imbottitura e poi fissata con punti metallici. Il cuscino del sedile e dello schienale sono amovibili e rivestiti con fodera dotata di zip. Poltrona e divani sono proposti con 4 piedi realizzati in acciaio cromato (CR), oppure con finitura nera (N) o bianca (BI), dotati di scivoli in plastica adatti a ogni tipo di pavimento.

Easy chair, 2- and 3-seater sofas and benches with spruce wood framework, covered with engineered wood panels. The elastic webbing on the seat assure that it provides the right support. The spruce structure is then covered with a number of layers of polyurethane with different thicknesses and densities based on the position. Seat and backrest cushions are removable and are padded with a thick layer of non-deformable polyurethane to ensure comfort.

The upholstery is fitted onto the wooden insert, which has been padded then secured with staples. The seat and backrest cushions are removable and have zip-up covers.

Easy chair and sofas come with 4 feet from chrome (CR) steel, or with black (N) or white (BI) finish, fitted with plastic glides and suitable for all floor surfaces.

Fauteuil, canapés 2 et 3 places et banquettes avec châssis portant en bois de sapin, recouvert de panneaux en bois aggloméré. Les sangles élastiques situées sous l'assise garantissent un soutien correct. Plusieurs couches de mousse de polyuréthane de différentes épaisseurs et densités sont appliquées sur la structure en sapin selon la position des coussins de l'assise et du dossier qui sont amovibles et sont rembourrés en mousse de polyuréthane indeformable épaisse pour en garantir le confort.

Le revêtement est enfilé sur l'insert en bois muni du rembourrage puis fixée avec des agrafes métalliques. Les coussins de l'assise et du dossier sont amovibles et revêtus avec une housse munie de zip.

Le fauteuil et les canapés sont proposés avec 4 pieds réalisés en acier chromé (CR), ou avec finition noire (N) ou blanche (BI), munis de patins en plastique adaptés à tous les sols.

Sessel, Zwei- und Dreisitzersofas und Bänke mit Gestell aus Fichtenholz, verkleidet mit Holzwerkstoffplatten. Die Sitzunterfederung mit Elastikgurten sorgt für die gute Tragfähigkeit des Sitzes. Auf die Struktur aus Fichtenholz werden dann verschiedene Schichten aus PU-Schaum mit je nach Position unterschiedlichen Dicken und Dichten aufgebracht. Sitz- und Rückenissen sind abnehmbar und mit nicht verformbarem PU-Schaumstoff gepolstert, dessen Dicke den Komfort gewährleistet.

Der Bezug wird auf die mit der Polsterung vorbereitete Holzeinlage aufgelegt und mit Metallstiften befestigt. Sitz- und Rückenissen sind abnehmbar und mit Reißverschlussbezug versehen.

Sessel und Sofas sind mit 4 Stahlfüßen in den Ausführungen verchromt (CR), schwarz (N) oder weiß (BI) sowie mit Kunststoffgleitern für alle Böden ausgestattet.

Piedi in acciaio | Steel feet | Pieds en acier | Stahlfüße



Finitura piedi | Feet finish | Finition pieds | Füße fering

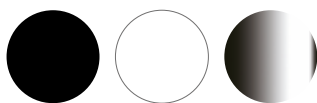

N

BI

CR

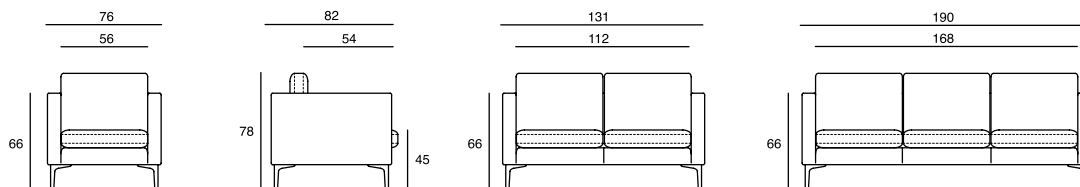

LOUNGE / WAITING

QUADRO



Conforme alla norma UNI EN 16139 livello 1
 Conforms the EN 16139 1st level standards
 Conforme aux normes EN 16139 1^{er} niveau
 Erfüllt die Anforderungen der Norm DIN EN 16139 Stufe 1



1/IM = Disponibile per alcuni rivestimenti a cartella
 Available for some covering only
 À disposition que pour quelque revêtement
 Erhältlich für einige Bezüge nach Stoff-Mustermappe

Serie per attesa, composta da poltrona a un posto e da divano a due posti, realizzati con un' intelaiatura portante in truciolare di pioppo a cui vengono applicati con colla e chiodi dei pannelli anch'essi pioppo. Le cinghie elastiche poste sul sedile garantiscono la corretta portanza della seduta. Il tutto è poi imbottito con gomma poliuretanic a spessori differenziati. La tappezzeria è calzata sull'inserto ligneo preparato con l'imbottitura e poi fissata con punti metallici. Il cuscino del sedile è amovibile e rivestito con fodera dotata di zip.

Poltrona e divano, sono dotati di 4 piedini in alluminio pressofuso, finitura satinata.

Waiting room series formed of a 1-seater easy chair and 2-seater sofa; the framework is made from poplar chipboard, with poplar panels glued and nailed onto the chipboard. The elastic webbing on the seat assure that it provides the right support. Everything is then padded with layers of different thickness polyurethane foam. The upholstery is fitted onto the wooden insert, which has been padded then secured with staples. The seat cushion is removable with zip-up cover.

Easy chair and sofa are fitted with 4, die-cast aluminium feet, with satin finish.

Série pour l'attente, composée d'un fauteuil et d'un canapé à deux places, réalisés avec un châssis portant en aggloméré de peuplier auxquels sont appliqués, avec de la colle et des clous, des panneaux eux aussi en peuplier. Les sangles élastiques situées sous l'assise garantissent un soutien correct. Le tout est ensuite rembourré de mousse de polyuréthane de densité variable. Le revêtement est enfilé sur l'insert en bois muni du rembourrage puis fixée avec des agrafes métalliques. Le coussin de l'assise est amovible et revêtu d'une housse munie de zip.

Le fauteuil et le canapé sont munis de 4 pieds en aluminium moulé sous pression, finition satinée.

Reihe für den Wartebereich, bestehend aus einem Sessel und einem Zweisitzersofa mit Trägerrahmen aus Pappelsperholz, auf den Platten, ebenfalls aus Pappelholz mit Leim und Nägeln aufgebracht werden. Die Sitzunterfederung mit Elastikgurten sorgt für die gute Tragfähigkeit des Sitzes. Das Ganze wird dann mit Schichten aus PU-Schaumstoff in verschiedenen Dicken gepolstert. Der Bezug wird auf die mit der Polsterung vorbereitete Holzeinlage aufgelegt und mit Metallstiften befestigt. Das Sitzkissen ist abnehmbar und mit Reißverschlussbezug versehen. Die 4 Füße sind aus satiniertem Aluminiumdruckguss.

Piedi in alluminio spazzolato | Feet in brushed aluminium | Patins en aluminium brossé | Füße aus rostigem Aluminium

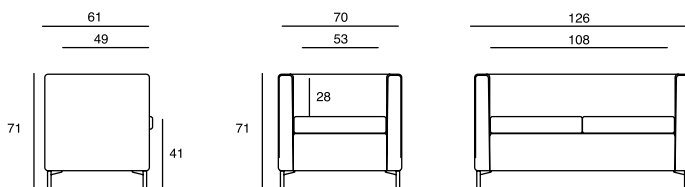



EN

Sesta is particularly attentive to the theme of **environmental protection**, starting from product concept and consequently the choice of materials, favouring materials with a high percentage of **recycled or recyclable material** or, as in the case of Polyurethane upholstery, opting for innovative materials and production that favour the use of natural materials such as **soy-based polyols** (30% use in cold-foamed flexible Polyurethane).

FR

Sesta accorde une attention particulière à la **protection de l'environnement**, dès le moment de la conception du produit et donc du choix des matériaux, en favorisant les matériaux ayant un pourcentage élevé de **matériaux recyclés ou recyclables** ou, comme dans le cas des revêtements en polyuréthane, en choisissant des matériaux innovants et des productions qui privilégient l'utilisation de matériaux naturels tels que les **polyols dérivés du soja** (utilisation de 30% dans les mousses de polyuréthane souple injectées à froid).

D

Besonderes Augenmerk legt Sesta auf das Thema Umweltschutz, angefangen bei der Konzeption der Produkte und damit bei der Auswahl der Materialien. So kommen bevorzugt **recycelte oder recycelbare Materialien** zur Verwendung oder, wie bei den Polsterungen aus Polyurethan, innovative Werkstoffe und Produktionsverfahren, die Naturstoffe wie beispielsweise **Soja-basiertes Polyol favorisieren** (30 prozentiger Einsatz in den PUR-Kaltschäumen).



Sesta presta una particolare attenzione al tema della **Tutela Ambientale**, a partire dalla concezione dei prodotti e quindi dalla scelta dei materiali, privilegiando i materiali con alta percentuale di materia riciclata o riciclabile oppure, come nel caso degli imbottiti in Poliuretano, scegliendo materiali e produzioni innovative che privilegiano l'impiego di materiali naturali come ad esempio polioli derivati dalla Soia (impiego al 30% negli schiumati a freddo di Poliuretano flessibile).

Sesta Srl
via Lombardia 32
26854 Cornegliano Laudense (Lodi) Italy
tel. +39 0371 483158
info@sesta.it



www.sesta.it

MOD. UNICO COLLECTION / JULY 2024